

DAQ

PCI-1200 User Manual

Multifunctional I/O Board for PCI Bus Computers

January 1997 Edition
Part Number 320942B-01



Internet Support

support@natinst.com

E-mail: info@natinst.com

FTP Site: ftp.natinst.com

Web Address: <http://www.natinst.com>



Bulletin Board Support

BBS United States: (512) 794-5422

BBS United Kingdom: 01635 551422

BBS France: 01 48 65 15 59



Fax-on-Demand Support

(512) 418-1111



Telephone Support (U.S.)

Tel: (512) 795-8248

Fax: (512) 794-5678



International Offices

Australia 03 9879 5166, Austria 0662 45 79 90 0, Belgium 02 757 00 20,

Canada (Ontario) 905 785 0085, Canada (Québec) 514 694 8521, Denmark 45 76 26 00,

Finland 09 527 2321, France 01 48 14 24 24, Germany 089 741 31 30, Hong Kong 2645 3186,

Israel 03 5734815, Italy 02 413091, Japan 03 5472 2970, Korea 02 596 7456,

Mexico 5 520 2635, Netherlands 0348 433466, Norway 32 84 84 00, Singapore 2265886,

Spain 91 640 0085, Sweden 08 730 49 70, Switzerland 056 200 51 51, Taiwan 02 377 1200,

U.K. 01635 523545

National Instruments Corporate Headquarters

6504 Bridge Point Parkway Austin, TX 78730-5039 Tel: (512) 794-0100

Important Information

Warranty

The PCI-1200 is warranted against defects in materials and workmanship for a period of one year from the date of shipment, as evidenced by receipts or other documentation. National Instruments will, at its option, repair or replace equipment that proves to be defective during the warranty period. This warranty includes parts and labor.

The media on which you receive National Instruments software are warranted not to fail to execute programming instructions, due to defects in materials and workmanship, for a period of 90 days from date of shipment, as evidenced by receipts or other documentation. National Instruments will, at its option, repair or replace software media that do not execute programming instructions if National Instruments receives notice of such defects during the warranty period. National Instruments does not warrant that the operation of the software shall be uninterrupted or error free.

A Return Material Authorization (RMA) number must be obtained from the factory and clearly marked on the outside of the package before any equipment will be accepted for warranty work. National Instruments will pay the shipping costs of returning to the owner parts which are covered by warranty.

National Instruments believes that the information in this manual is accurate. The document has been carefully reviewed for technical accuracy. In the event that technical or typographical errors exist, National Instruments reserves the right to make changes to subsequent editions of this document without prior notice to holders of this edition. The reader should consult National Instruments if errors are suspected. In no event shall National Instruments be liable for any damages arising out of or related to this document or the information contained in it.

EXCEPT AS SPECIFIED HEREIN, NATIONAL INSTRUMENTS MAKES NO WARRANTIES, EXPRESS OR IMPLIED, AND SPECIFICALLY DISCLAIMS ANY WARRANTY OF MERCHANTABILITY OR FITNESS FOR A PARTICULAR PURPOSE. CUSTOMER'S RIGHT TO RECOVER DAMAGES CAUSED BY FAULT OR NEGLIGENCE ON THE PART OF NATIONAL INSTRUMENTS SHALL BE LIMITED TO THE AMOUNT THEREFORE PAID BY THE CUSTOMER. NATIONAL INSTRUMENTS WILL NOT BE LIABLE FOR DAMAGES RESULTING FROM LOSS OF DATA, PROFITS, USE OF PRODUCTS, OR INCIDENTAL OR CONSEQUENTIAL DAMAGES, EVEN IF ADVISED OF THE POSSIBILITY THEREOF. This limitation of the liability of National Instruments will apply regardless of the form of action, whether in contract or tort, including negligence. Any action against National Instruments must be brought within one year after the cause of action accrues. National Instruments shall not be liable for any delay in performance due to causes beyond its reasonable control. The warranty provided herein does not cover damages, defects, malfunctions, or service failures caused by owner's failure to follow the National Instruments installation, operation, or maintenance instructions; owner's modification of the product; owner's abuse, misuse, or negligent acts; and power failure or surges, fire, flood, accident, actions of third parties, or other events outside reasonable control.

Copyright

Under the copyright laws, this publication may not be reproduced or transmitted in any form, electronic or mechanical, including photocopying, recording, storing in an information retrieval system, or translating, in whole or in part, without the prior written consent of National Instruments Corporation.

Trademarks

LabVIEW[®], NI-DAQ[®], ComponentWorks[™], CVI[™], Measure[™], MITE[™], SCXI[™], and VirtualBench[™] are trademarks of National Instruments Corporation.

Product and company names listed are trademarks or trade names of their respective companies.

WARNING REGARDING MEDICAL AND CLINICAL USE OF NATIONAL INSTRUMENTS PRODUCTS

National Instruments products are not designed with components and testing intended to ensure a level of reliability suitable for use in treatment and diagnosis of humans. Applications of National Instruments products involving medical or clinical treatment can create a potential for accidental injury caused by product failure, or by errors on the part of the user or application designer. Any use or application of National Instruments products for or involving medical or clinical treatment must be performed by properly trained and qualified medical personnel, and all traditional medical safeguards, equipment, and procedures that are appropriate in the particular situation to prevent serious injury or death should always continue to be used when National Instruments products are being used. National Instruments products are NOT intended to be a substitute for any form of established process, procedure, or equipment used to monitor or safeguard human health and safety in medical or clinical treatment.



*Table
of
Contents*

About This Manual

Organization of This Manual	ix
Conventions Used in This Manual	x
National Instruments Documentation	xi
Related Documentation	xii
Customer Communication	xii

Chapter 1

Introduction

About the PCI-1200	1-1
What You Need to Get Started	1-1
Software Programming Choices	1-2
National Instruments Application Software	1-2
NI-DAQ Driver Software	1-3
Register-Level Programming	1-4
Optional Equipment	1-5
Custom Cabling	1-5
Unpacking	1-6

Chapter 2

Installation and Configuration

Software Installation	2-1
Hardware Installation	2-1
Board Configuration	2-2
Analog I/O Configuration	2-2
Analog Output Polarity	2-3
Analog Input Polarity	2-3
Analog Input Mode	2-3
RSE Input (Eight Channels, Reset Condition)	2-4
NRSE Input (Eight Channels)	2-4
DIFF Input (Four Channels)	2-5

Chapter 3

Signal Connections

I/O Connector	3-1
Signal Connection Descriptions	3-3
Analog Input Signal Connections	3-5
Types of Signal Sources	3-7
Floating Signal Sources	3-7
Ground-Referenced Signal Sources	3-7
Input Configurations	3-8
Differential Connection Considerations	
(DIFF Configuration)	3-10
Differential Connections for Grounded Signal Sources	3-10
Differential Connections for Floating Signal Sources	3-11
Single-Ended Connection Considerations	3-13
Single-Ended Connections for Floating Signal Sources	
(RSE Configuration)	3-13
Single-Ended Connections for Grounded Signal Sources	
(NRSE Configuration)	3-14
Common-Mode Signal Rejection Considerations	3-15
Analog Output Signal Connections	3-16
Digital I/O Signal Connections	3-17
Logical Inputs and Outputs	3-18
Port C Pin Connections	3-19
Timing Specifications	3-20
Mode 1 Input Timing	3-22
Mode 1 Output Timing	3-23
Mode 2 Bidirectional Timing	3-24
DAQ and General Purpose Timing Signal Connections	3-25
DAQ Timing Connections	3-25
General Purpose Timing Signal Connections	3-29
Power Connections	3-33

Chapter 4

Theory of Operation

Functional Overview	4-1
PCI Interface Circuitry	4-2
Timing	4-3
Analog Input	4-5
Analog Input Circuitry	4-6
DAQ Operations	4-7
Controlled Acquisition Mode	4-8

Freerun Acquisition Mode	4-8
Interval Scanning Acquisition Mode	4-8
Single-Channel Data Acquisition.....	4-9
Multichannel Scanned Data Acquisition.....	4-9
DAQ Rates.....	4-10
Analog Output.....	4-11
Analog Output Circuitry.....	4-12
DAC Timing.....	4-12
Digital I/O.....	4-12

Chapter 5

Calibration

Calibration at Higher Gains	5-2
Calibration Equipment Requirements.....	5-2
Using the Calibration Function	5-3

Appendix A

Specifications

Appendix B

Customer Communication

Glossary

Index

Figures

Figure 1-1. The Relationship between the Programming Environment, NI-DAQ, and Your Hardware	1-4
Figure 3-1. PCI-1200 I/O Connector Pin Assignments	3-2
Figure 3-2. PCI-1200 Instrumentation Amplifier.....	3-6
Figure 3-3. Differential Input Connections for Grounded Signal Sources.....	3-11
Figure 3-4. Differential Input Connections for Floating Sources.....	3-12
Figure 3-5. Single-Ended Input Connections for Floating Signal Sources	3-14
Figure 3-6. Single-Ended Input Connections for Grounded Signal Sources.....	3-15
Figure 3-7. Analog Output Signal Connections	3-17
Figure 3-8. Digital I/O Connections	3-19
Figure 3-9. Mode 1 Timing Specifications for Input Transfers	3-22

Figure 3-10.	Mode 1 Timing Specifications for Output Transfers	3-23
Figure 3-11.	Mode 2 Timing Specification for Bidirectional Transfers	3-24
Figure 3-12.	EXTCONV* Signal Timing	3-25
Figure 3-13.	Posttrigger DAQ Timing	3-26
Figure 3-14.	Pretrigger DAQ Timing.....	3-27
Figure 3-15.	Interval-Scanning Signal Timing	3-28
Figure 3-16.	EXTUPDATE* Signal Timing for Updating DAC Output	3-29
Figure 3-17.	Event-Counting Application with External Switch Gating	3-30
Figure 3-18.	Frequency Measurement Application.....	3-31
Figure 3-19.	General Purpose Timing Signals.....	3-33
Figure 4-1.	PCI-1200 Block Diagram	4-1
Figure 4-2.	PCI Interface Circuitry	4-3
Figure 4-3.	Timing Circuitry.....	4-4
Figure 4-4.	Analog Input Circuitry	4-5
Figure 4-5.	Analog Output Circuitry.....	4-11
Figure 4-6.	Digital I/O Circuitry	4-13

Tables

Table 2-1.	Analog I/O Settings	2-2
Table 2-2.	Analog Input Modes for the PCI-1200.....	2-4
Table 3-1.	Signal Descriptions for PCI-1200 I/O Connector Pins.....	3-3
Table 3-2.	Bipolar Analog Input Signal Range Versus Gain.....	3-5
Table 3-3.	Unipolar Analog Input Signal Range Versus Gain	3-6
Table 3-4.	Summary of Analog Input Connections	3-9
Table 3-5.	Port C Signal Assignments.....	3-20
Table 3-6.	Signal Names Used in Timing Diagrams	3-20
Table 4-1.	Analog Input Settling Time Versus Gain	4-10
Table 4-2.	PCI-1200 Maximum Recommended DAQ Rates	4-11

This manual describes the electrical and mechanical aspects of the PCI-1200 and contains information concerning its operation and programming.

The PCI-1200 is a low-cost multifunction analog, digital, and timing board. The PCI-1200 is a member of the National Instruments PCI Series of expansion boards for PCI bus computers. These boards are designed for high-performance data acquisition (DAQ) and control for applications in laboratory testing, production testing, and industrial process monitoring and control.

Organization of This Manual

The *PCI-1200 User Manual* is organized as follows:

- Chapter 1, *Introduction*, describes the PCI-1200, lists what you need to get started, software programming choices, and optional equipment, and explains how to build custom cables and unpack the PCI-1200.
- Chapter 2, *Installation and Configuration*, describes how to install and configure your PCI-1200.
- Chapter 3, *Signal Connections*, describes how to make input and output signal connections to the PCI-1200 board via the board I/O connector and details the I/O timing specifications.
- Chapter 4, *Theory of Operation*, explains the operation of each functional unit of the PCI-1200.
- Chapter 5, *Calibration*, discusses the calibration procedures for the PCI-1200 analog I/O circuitry.
- Appendix A, *Specifications*, lists the PCI-1200 specifications.
- Appendix B, *Customer Communication*, contains forms you can use to request help from National Instruments or to comment on our products.

- The *Glossary* contains an alphabetical list and description of terms used in this manual, including abbreviations, acronyms, definitions, metric prefixes, mnemonics, and symbols.
- The *Index* contains an alphabetical list of key terms and topics in this manual, including the page where you can find each one.

Conventions Used in This Manual

The following conventions are used in this manual:

bold	Bold text denotes menus, menu items, or dialog box buttons or options.
<i>italic</i>	Italic text denotes emphasis, a cross reference, or an introduction to a key concept.
<i>bold italic</i>	Bold italic text denotes a note, caution, or warning.
Macintosh	Macintosh refers to all Macintosh computers with PCI bus, unless otherwise noted.
monospace	Text in this font denotes text or characters that are to be literally input from the keyboard, sections of code, programming examples, and syntax examples. This font is also used for the proper names of disk drives, paths, directories, programs, subprograms, subroutines, device names, functions, variables, filenames, and extensions, and for statements and comments taken from program code.
PC	PC refers to all IBM PC/XT, PC/AT and compatible computers with PCI bus, unless otherwise noted.
NI-DAQ	NI-DAQ is used in this manual to refer to the NI-DAQ software for PC or Macintosh computers, unless otherwise noted.
SCXI	SCXI stands for Signal Conditioning eXtensions for Instrumentation and is a National Instruments product line designed to perform front-end signal conditioning for National Instruments plug-in DAQ boards.
< >	Angle brackets containing numbers separated by an ellipses represent a range of values associated with a bit, signal or port (for example, ACH<0..7> stands for ACH0 through ACH7).
	Abbreviations, acronyms, definitions, metric prefixes, mnemonics, symbols, and terms are listed in the <i>Glossary</i> .

National Instruments Documentation

The *PCI-1200 User Manual* is one piece of the documentation set for your DAQ system. You could have any of several types of manuals, depending on the hardware and software in your system. Use the manuals you have as follows:

- *Getting Started with SCXI*—If you are using SCXI, this is the first manual you should read. It gives an overview of the SCXI system and contains the most commonly needed information for the modules, chassis, and software.
- Your SCXI hardware user manuals—If you are using SCXI, read these manuals next for detailed information about signal connections and module configuration. They also explain in greater detail how the module works and contain application hints.
- Your DAQ hardware user manuals—These manuals have detailed information about the DAQ hardware that plugs into or is connected to your computer. Use these manuals for hardware installation and configuration instructions, specification information about your DAQ hardware, and application hints.
- Software documentation—Examples of software documentation you may have are the LabVIEW or LabWindows®/CVI documentation sets and the NI-DAQ documentation. After you set up your hardware system, use either the application software (LabVIEW or LabWindows/CVI) or the NI-DAQ documentation to help you write your application. If you have a large and complicated system, it is worthwhile to look through the software documentation before you configure your hardware.
- Accessory installation guides or manuals—If you are using accessory products, read the terminal block and cable assembly installation guides and accessory board user manuals. They explain how to physically connect the relevant pieces of the system. Consult these guides when you are making your connections.
- *SCXI Chassis Manual*—If you are using SCXI, read this manual for maintenance information on the chassis and installation instructions.

Related Documentation

The following National Instruments document contains information that you may find helpful as you read this manual:

- Application Note 025, *Field Wiring and Noise Considerations for Analog Signals*

The following documents also contain information that you may find helpful as you read this manual:

- “Dither in Digital Audio,” by John Vanderkooy and Stanley P. Lipshitz, *Journal of the Audio Engineering Society*, Vol. 35, No. 12, December 1987.
- *PCI Local Bus Specification, Revision 2.0*
- Your computer’s technical reference manual

The following National Instruments document contains detailed information for the register-level programmer:

- *PCI-1200 Register-Level Programmer Manual*

This manual is available from National Instruments by request. If you are using NI-DAQ, LabVIEW, LabWindows/CVI, or other application software, you should not need the register-level programmer manual. Using NI-DAQ, LabVIEW, LabWindows/CVI or other application software, is easier than, and as flexible as, using the low-level programming described in the register-level programmer manual. Refer to the *Software Programming Choices* section in Chapter 1, *Introduction*, of this manual to learn about your programming options.

Customer Communication

National Instruments wants to receive your comments on our products and manuals. We are interested in the applications you develop with our products, and we want to help if you have problems with them. To make it easy for you to contact us, this manual contains comment and configuration forms for you to complete. These forms are in Appendix B, *Customer Communication*, at the end of this manual.

Introduction

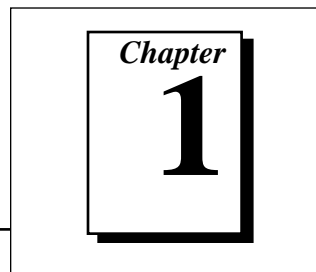

This chapter describes the PCI-1200, lists what you need to get started, software programming choices, and optional equipment, and explains how to build custom cables and unpack the PCI-1200.

About the PCI-1200

Thank you for purchasing the PCI-1200, a low-cost, high-performance multifunction analog, digital, and timing board for PCI bus computers. The PCI-1200 has eight analog input channels that you can configure as eight single-ended or four differential inputs; a 12-bit successive-approximation ADC; two 12-bit DACs with voltage outputs; 24 lines of TTL-compatible digital I/O; and three 16-bit counter/timers for timing I/O.

The PCI-1200 is a member of the National Instruments PCI Series of expansion boards for PCI bus computers. These boards are designed for high-performance data acquisition and control for applications in laboratory testing, production testing, and industrial process monitoring and control.

Detailed PCI-1200 specifications are in Appendix A, *Specifications*.

What You Need to Get Started

To set up and use your PCI-1200, you will need the following:

- PCI-1200 board
- PCI-1200 User Manual*

- One of the following software packages and documentation:
 - ComponentWorks
 - LabVIEW for Macintosh
 - LabVIEW for Windows
 - LabWindows/CVI for Windows
 - Measure
 - NI-DAQ for Macintosh
 - NI-DAQ for PC compatibles
 - VirtualBench

- Your computer

Software Programming Choices

There are several options to choose from when programming your National Instruments DAQ or SCXI hardware. You can use LabVIEW, LabWindows/CVI, ComponentWorks, VirtualBench, NI-DAQ, or register-level programming.

National Instruments Application Software

ComponentWorks contains tools for data acquisition and instrument control built on NI-DAQ driver software. ComponentWorks provides a higher-level programming interface for building virtual instruments through standard OLE controls and DLLs. With ComponentWorks, you can use all of the configuration tools, resource management utilities, and interactive control utilities included with NI-DAQ.

LabVIEW features interactive graphics, a state-of-the-art user interface, and a powerful graphical programming language. The LabVIEW Data Acquisition Virtual Instrument (VI) Library, a series of VIs for using LabVIEW with National Instruments DAQ hardware, is included with LabVIEW. The LabVIEW Data Acquisition VI Library is functionally equivalent to the NI-DAQ software.

LabWindows/CVI features interactive graphics, a state-of-the-art user interface, and uses the ANSI standard C programming language. The LabWindows/CVI Data Acquisition Library, a series of functions for using LabWindows/CVI with National Instruments DAQ hardware, is included with the NI-DAQ software kit. The LabWindows/CVI Data Acquisition Library is functionally equivalent to the NI-DAQ software.

VirtualBench features VIs that combine DAQ products, software, and your computer to create a stand-alone instrument with the added benefit of the processing, display, and storage capabilities of your computer. VirtualBench instruments load and save waveform data to disk in the same forms that can be used in popular spreadsheet programs and word processors.

Using ComponentWorks, LabVIEW, LabWindows/CVI, or VirtualBench software will greatly reduce the development time for your data acquisition and control application.

NI-DAQ Driver Software

The NI-DAQ driver software is included at no charge with all National Instruments DAQ hardware. NI-DAQ is not packaged with SCXI or accessory products, except for the SCXI-1200. NI-DAQ has an extensive library of functions that you can call from your application programming environment. These functions include routines for analog input (A/D conversion), buffered data acquisition (high-speed A/D conversion), analog output (D/A conversion), waveform generation (timed D/A conversion), digital I/O, counter/timer operations, SCXI, RTSI, self-calibration, messaging, and acquiring data to memory.

NI-DAQ has both high-level DAQ I/O functions for maximum ease of use and low-level DAQ I/O functions for maximum flexibility and performance. Examples of high-level functions are streaming data to disk or acquiring a certain number of data points. An example of a low-level function is writing directly to registers on the DAQ device. NI-DAQ does not sacrifice the performance of National Instruments DAQ devices because it lets multiple devices operate at their peak performance.

NI-DAQ also internally addresses many of the complex issues between the computer and the DAQ hardware such as programming interrupts and DMA controllers. NI-DAQ maintains a consistent software interface among its different versions so that you can change platforms with minimal modifications to your code. Whether you are using conventional programming languages, LabVIEW, LabWindows/CVI, or other application software, your application uses the NI-DAQ driver software, as illustrated in Figure 1-1.

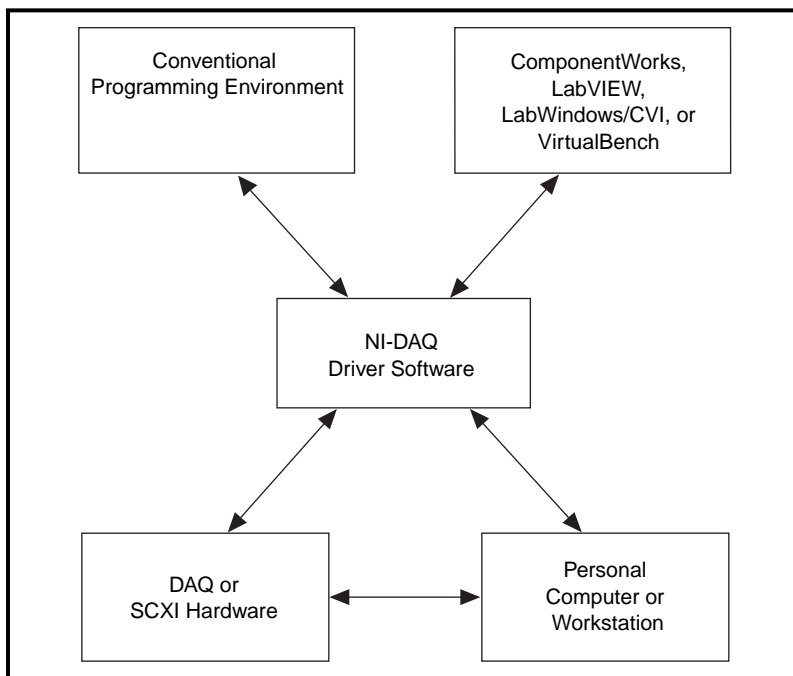

Figure 1-1. The Relationship between the Programming Environment, NI-DAQ, and Your Hardware

Register-Level Programming

The final option for programming any National Instruments DAQ hardware is to write register-level software. Writing register-level programming software can be very time-consuming and inefficient, and is not recommended for most users.

Even if you are an experienced register-level programmer, consider using NI-DAQ, LabVIEW, LabWindows/CVI or other National Instruments application software to program your National Instruments DAQ hardware. Using the National Instruments application software is easier than, and as flexible as, register-level programming, and can save weeks of development time.

Optional Equipment

National Instruments offers a variety of products to use with your PCI-1200 board, including cables, connector blocks, and other accessories, as follows:

- Cables and cable assemblies
- Connector blocks, 50-pin screw terminals
- SCXI modules and accessories for isolating, amplifying, exciting, and multiplexing signals for relays and analog output. With SCXI you can condition and acquire up to 3,072 channels.
- Low channel count signal conditioning modules, boards, and accessories, including conditioning for strain gauges and RTDs, simultaneous sample and hold, and relays

For more information about optional equipment available from National Instruments, refer to your National Instruments catalogue or call the office nearest you.

Custom Cabling

National Instruments offers cables and accessories for you to prototype your application or to use if you frequently change board interconnections.

If you want to develop your own cable, however, the following guidelines may be useful:

- For the analog input signals, shielded twisted-pair wires for each analog input pair yield the best results, assuming that you use differential inputs. Tie the shield for each signal pair to the ground reference at the source.
- You should route the analog lines separately from the digital lines.
- When using a cable shield, use separate shields for the analog and digital halves of the cable. Failure to do so results in noise coupling into the analog signals from transient digital signals.

The mating connector for the PCI-1200 is a 50-position, polarized, ribbon socket connector with strain relief. National Instruments uses a polarized (keyed) connector to prevent inadvertent upside-down connection to the PCI-1200. Recommended manufacturer part numbers for this mating connector are as follows:

- Electronic Products Division/3M (part number 3425-7650)
- T&B/Ansley Corporation (part number 609-5041CE)

Unpacking

Your PCI-1200 is shipped in an antistatic package to prevent electrostatic damage to the board. Electrostatic discharge can damage several components on the board. To avoid such damage in handling the board, take the following precautions:

- Ground yourself via a grounding strap or by holding a grounded object.
- Touch the antistatic package to a metal part of your computer chassis before removing the board from the package.
- Remove the board from the package and inspect the board for loose components or any other sign of damage. Notify National Instruments if the board appears damaged in any way. *Do not* install a damaged board into your computer.
- *Never* touch the exposed pins of connectors.

Installation and Configuration

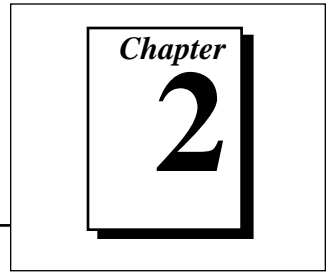

This chapter describes how to install and configure your PCI-1200.

Software Installation

If you are using NI-DAQ, or National Instruments application software, refer to the installation instructions in your software documentation to install and configure your software.

If you are a register-level programmer, refer to the *PCI-1200 Register-Level Programmer Manual*.

Hardware Installation

The PCI-1200 can be installed in any unused PCI expansion slot in your computer.

The following are general installation instructions. Consult the user manual or technical reference manual for your computer for specific instructions and warnings.

1. Turn off your computer.
2. Remove the top cover or access port to the I/O channel.
3. Remove the expansion slot cover on the back panel of the computer.
4. Insert the PCI-1200 in an unused 5 V PCI slot. The fit may be tight, but *do not* force the board into place.
5. Screw the PCI-1200 mounting bracket to the back panel rail of the computer or use the slot side tabs, if available, to secure the PCI-1200 in place.
6. Replace the top cover on the computer.

The PCI-1200 board is installed.

Board Configuration

The PCI-1200 is completely software configurable. The PCI-1200 is fully compliant with the *PCI Local Bus Specification*, Revision 2.0. Therefore, all board resources are automatically allocated by the system. For the PCI-1200, this allocation includes the base memory address and interrupt level. You do not need to perform any configuration steps after the system powers up.

Analog I/O Configuration

Upon power-up or after a software reset, the PCI-1200 is set to the following configuration:

- Referenced single-ended input mode
- ± 5 V analog input range (bipolar)
- ± 5 V analog output range (bipolar)

Table 2-1 lists all the available analog I/O configurations for the PCI-1200 and shows the configuration in reset condition.

Table 2-1. Analog I/O Settings

Parameter	Configuration
Analog Output CH0 Polarity	Bipolar— ± 5 V (reset condition) Unipolar—0 to 10 V
Analog Output CH1 Polarity	Bipolar— ± 5 V (reset condition) Unipolar—0 to 10 V
Analog Input Polarity	Bipolar— ± 5 V (reset condition) Unipolar—0 to 10 V
Analog Input Mode	Referenced single-ended (RSE) (reset condition) Nonreferenced single-ended (NRSE) Differential (DIFF)

Both the analog input and analog output circuitries are software configurable. Refer to your software documentation for more information on changing these settings.

Analog Output Polarity

The PCI-1200 has two channels of analog output voltage at the I/O connector. You can configure each analog output channel for either unipolar or bipolar output. A unipolar configuration has a range of 0 to 10 V at the analog output. A bipolar configuration has a range of -5 to +5 V at the analog output. In addition, you can select the coding scheme for each D/A converter (DAC) as either two's complement or straight binary. If you select a bipolar range for a DAC, the two's complement coding is recommended. In this mode, data values written to the analog output channel range from F800 hex (-2,048 decimal) to 7FF hex (2,047 decimal). If you select a unipolar range for a DAC, the straight binary coding is recommended. In this mode, data values written to the analog output channel range from 0 to FFF hex (4,095 decimal).

Analog Input Polarity

You can select the analog input on the PCI-1200 for either a unipolar range (0 to 10 V) or a bipolar range (-5 to +5 V). In addition, you can select the coding scheme for analog input as either two's complement or straight binary. If you select a bipolar range, the two's complement coding is recommended. In this mode, -5 V input corresponds to F800 hex (-2,048 decimal) and +5 V corresponds to 7FF hex (2,047 decimal). If you select a unipolar mode, the straight binary coding is recommended. In this mode, 0 V input corresponds to 0 hex, and +10 V corresponds to FFF hex (4,095 decimal).

Analog Input Mode

The PCI-1200 has three different input modes—RSE input, NRSE input, and DIFF input. The single-ended input configurations use eight channels. The DIFF input configuration uses four channels. Table 2-2 describes these configurations.

Table 2-2. Analog Input Modes for the PCI-1200

Analog Input Modes	Description
RSE	RSE mode provides eight single-ended inputs with the negative input of the instrumentation amplifier referenced to analog ground (reset condition).
NRSE	NRSE mode provides eight single-ended inputs with the negative input of the instrumentation amplifier tied to AISENSE/AIGND and not connected to ground.
DIFF	DIFF mode provides four differential inputs with the positive input of the instrumentation amplifier tied to channels 0, 2, 4, or 6 and the negative input tied to channels 1, 3, 5, or 7, respectively, thus choosing channel pairs (0, 1), (2, 3), (4, 5), or (6, 7).

While reading the following paragraphs, you may find it helpful to refer to the *Analog Input Signal Connections* section of Chapter 3, *Signal Connections*, which contains diagrams showing the signal paths for the three configurations.

RSE Input (Eight Channels, Reset Condition)

RSE input means that all input signals are referenced to a common ground point that is also tied to the PCI-1200 analog input ground. The differential amplifier negative input is tied to analog ground. The RSE configuration is useful for measuring floating signal sources. With this input configuration, the PCI-1200 can monitor eight different analog input channels.

Considerations for using the RSE configuration are discussed in Chapter 3, *Signal Connections*. Notice that in this mode, the signal return path is analog ground at the connector through the AISENSE/AIGND pin.

NRSE Input (Eight Channels)

NRSE input means that all input signals are referenced to the same common-mode voltage, which floats with respect to the PCI-1200 analog ground. This common-mode voltage is subsequently subtracted by the input instrumentation amplifier. The NRSE configuration is useful for measuring ground-referenced signal sources.

Considerations for using the NRSE configuration are discussed in Chapter 3, *Signal Connections*. Notice that in this mode, the signal return path is through the negative terminal of the amplifier at the connector through the AISENSE/AIGND pin.

DIFF Input (Four Channels)

DIFF input means that each input signal has its own reference, and the difference between each signal and its reference is measured. The signal and its reference are each assigned an input channel. With this input configuration, the PCI-1200 can monitor four differential analog input signals.

Considerations for using the DIFF configuration are discussed in Chapter 3, *Signal Connections*. Notice that the signal return path is through the amplifier's negative terminal and through channel 1, 3, 5, or 7, depending on which channel pair you select.

Signal Connections

Chapter

3

This chapter describes how to make input and output signal connections to the PCI-1200 board via the board I/O connector and details the I/O timing specifications.

The I/O connector for the PCI-1200 has 50 pins that you can connect to 50-pin accessories.

I/O Connector

Figure 3-1 shows the pin assignments for the PCI-1200 I/O connector.



Warning: *Connections that exceed any of the maximum ratings of input or output signals on the PCI-1200 may damage the PCI-1200 and the computer. This includes connecting any power signals to ground and vice versa. National Instruments is NOT liable for any damages resulting from signal connections that exceed these maximum ratings.*

ACH0	1	2	ACH1
ACH2	3	4	ACH3
ACH4	5	6	ACH5
ACH6	7	8	ACH7
AISENSE/AIGND	9	10	DAC0OUT
AGND	11	12	DAC1OUT
DGND	13	14	PA0
PA1	15	16	PA2
PA3	17	18	PA4
PA5	19	20	PA6
PA7	21	22	PB0
PB1	23	24	PB2
PB3	25	26	PB4
PB5	27	28	PB6
PB7	29	30	PC0
PC1	31	32	PC2
PC3	33	34	PC4
PC5	35	36	PC6
PC7	37	38	EXTTRIG
EXTUPDATE*	39	40	EXTCONV*
OUTB0	41	42	GATB0
OUTB1	43	44	GATB1
CLKB1	45	46	OUTB2
GATB2	47	48	CLKB2
+5 V	49	50	DGND

Figure 3-1. PCI-1200 I/O Connector Pin Assignments

Signal Connection Descriptions

The following table describes the connector pins on the PCI-1200 I/O connector by pin number and gives the signal name and description of each signal connector pin.

Table 3-1. Signal Descriptions for PCI-1200 I/O Connector Pins

Pin	Signal Name	Direction	Reference	Description
1-8	ACH<7..0>	AI	AGND	Analog Channel 7 through 0—Analog input channels 0 through 7.
9	AISENSE/AIGND	I/O	AGND	Analog Input Sense/Analog Input Ground—Connected to AGND in RSE mode, analog input sense in NRSE mode.
10	DAC0OUT	AO	AGND	Digital-to-Analog Converter 0 Output—Voltage output signal for analog output channel 0.
11	AGND	N/A	N/A	Analog Ground—Analog output ground reference for analog output voltages. Bias current return point for differential measurements.
12	DAC1OUT	AO	AGND	Digital-to-Analog Converter 1 Output—Voltage output signal for analog output channel 1.
13, 50	DGND	N/A	N/A	Digital Ground—Voltage ground reference for the digital signals and the +5 V supply.
14-21	PA<7..0>	DIO	DGND	Port A 7 through 0—Bidirectional data lines for port A. PA7 is the MSB, and PA0 is the LSB.
22-29	PB<7..0>	DIO	DGND	Port B 7 through 0—Bidirectional data lines for port B. PB7 is the MSB, and PB0 is the LSB.
30-37	PC<7..0>	DIO	DGND	Port C 7 through 0—Bidirectional data lines for port C. PC7 is the MSB, and PC0 is the LSB.

Table 3-1. Signal Descriptions for PCI-1200 I/O Connector Pins (Continued)

Pin	Signal Name	Direction	Reference	Description
38	EXTTRIG	DI	DGND	External Trigger—External control signal to trigger a DAQ operation.
39	EXTUPDATE*	DI	DGND	External Update—External control signal to update DAC outputs.
40	EXTCONV*	DIO	DGND	External Convert—External control signal to time A/D conversions (DI) and drive SCANCLK when you use SCXI (DO).
41	OUTB0	DO	DGND	Output B0—Digital output signal of counter B0.
42	GATB0	DI	DGND	Gate B0—External control signal for gating counter B0.
43	OUTB1	DIO	DGND	Output B1—Digital output signal of counter B1 (DO). External control signal for timing a scan interval (DI).
44	GATB1	DI	DGND	Gate B1—External control signal for gating counter B1.
45	CLKB1	DI	DGND	Clock B1—External control clock signal for counter B1.
46	OUTB2	DO	DGND	Counter B2—Digital output signal of counter B2.
47	GATB2	DI	DGND	Gate B2—External control signal for gating counter B2.
48	CLKB2	DI	DGND	Clock B2—External control clock signal for counter B2.
49	+5 V	DO	DGND	+5 Volts—This pin is fused for up to 1 A of +4.65 to +5.25 V.
*Indicates that the signal is active low. AI = Analog Input DI = Digital Input DIO = Digital Input/Output AO = Analog Output DO = Digital Output N/A = Not Applicable				

The connector pins are grouped into analog input signal pins, analog output signal pins, digital I/O signal pins, timing I/O signal pins, and power connections. The following sections describe the signal connection guidelines for each of these groups.

Analog Input Signal Connections

Pins 1 through 8 are analog input signal pins for the 12-bit ADC. Pin 9, AISENSE/AIGND, is an analog common signal. You can use this pin for a general analog power ground tie to the PCI-1200 in RSE mode or as a return path in NRSE mode. Pin 11, AGND, is the bias current return point for differential measurements. Pins 1 through 8 are tied to the eight single-ended analog input channels of the input multiplexer through 4.7 k Ω series resistors. Pins 2, 4, 6, and 8 are also tied to an input multiplexer for DIFF mode.

The signal ranges for inputs ACH<7..0> at all possible gains are shown in Tables 3-2 and 3-3. Exceeding the input signal range will not damage the input circuitry as long as the maximum powered-on input voltage rating of ± 35 V or powered off voltage rating of ± 25 V is not exceeded. The PCI-1200 is guaranteed to withstand inputs up to the maximum input voltage rating.



Warning: *Exceeding the input signal range distorts input signals. Exceeding the maximum input voltage rating may damage the PCI-1200 board and the computer. National Instruments is NOT liable for any damages resulting from such signal connections.*

Table 3-2. Bipolar Analog Input Signal Range Versus Gain

Gain Setting	Input Signal Range
1	-5.0 to 4.99756 V
2	-2.5 to 2.49878 V
5	-1.0 to 0.99951 V
10	-500 to 499.756 mV
20	-250 to 249.877 mV
50	-100 to 99.951 mV
100	-50 to 49.975 mV

Table 3-3. Unipolar Analog Input Signal Range Versus Gain

Gain Setting	Input Signal Range
1	0 to 9.99756 V
2	0 to 4.99878 V
5	0 to 1.99951 V
10	0 to 999.756 mV
20	0 to 499.877 mV
50	0 to 199.951 mV
100	0 to 99.975 mV

How you connect analog input signals to the PCI-1200 depends on how you configure the PCI-1200 analog input circuitry and the type of input signal source. With different PCI-1200 configurations, you can use the PCI-1200 instrumentation amplifier in different ways. Figure 3-2 shows a diagram of the PCI-1200 instrumentation amplifier.

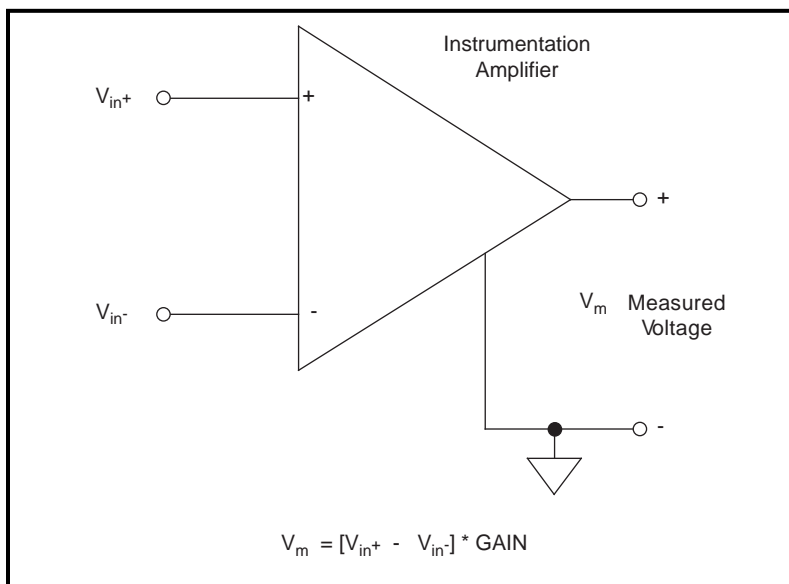

Figure 3-2. PCI-1200 Instrumentation Amplifier

The PCI-1200 instrumentation amplifier applies gain, common-mode voltage rejection, and high-input impedance to the analog input signals connected to the PCI-1200 board. Signals are routed to the positive and

negative inputs of the instrumentation amplifier through input multiplexers on the PCI-1200. The instrumentation amplifier converts two input signals to a signal that is the difference between the two input signals multiplied by the gain setting of the amplifier. The amplifier output voltage is referenced to the PCI-1200 ground. The PCI-1200 ADC measures this output voltage when it performs A/D conversions.

All signals must be referenced to ground, either at the source device or at the PCI-1200. If you have a floating source, you must use a ground-referenced input connection at the PCI-1200. If you have a grounded source, you must use a nonreferenced input connection at the PCI-1200.

Types of Signal Sources

When configuring the input mode of the PCI-1200 and making signal connections, first determine whether the signal source is floating or ground referenced. These two types of signals are described as follows.

Floating Signal Sources

A floating signal source is not connected in any way to the building ground system but has an isolated ground-reference point. Some examples of floating signal sources are outputs of transformers, thermocouples, battery-powered devices, optical isolator outputs, and isolation amplifiers. Tie the ground reference of a floating signal to the PCI-1200 analog input ground to establish a local or onboard reference for the signal. Otherwise, the measured input signal varies or appears to float. An instrument or device that supplies an isolated output falls into the floating signal source category.

Ground-Referenced Signal Sources

A ground-referenced signal source is connected in some way to the building system ground and is, therefore, already connected to a common ground point with respect to the PCI-1200, assuming that the computer is plugged into the same power system. Nonisolated outputs of instruments and devices that plug into the building power system fall into this category.

The difference in ground potential between two instruments connected to the same building power system is typically between 1 and 100 mV but can be much higher if power distribution circuits are not properly connected. The connection instructions that follow for grounded signal sources eliminate this ground potential difference from the measured signal.



Note: *If you power both the PCI-1200 and your computer with a floating power source (such as a battery), your system may be floating with respect to earth ground. In this case, treat all of your signal sources as floating sources.*

Input Configurations

You can configure the PCI-1200 for one of three input modes—RSE, NRSE, or DIFF. The following sections discuss the use of single-ended and differential measurements, and considerations for measuring both floating and ground-referenced signal sources. Table 3-4 summarizes the recommended input configurations for both types of signal sources.

Table 3-4. Summary of Analog Input Connections

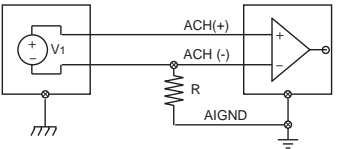
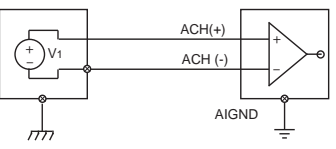
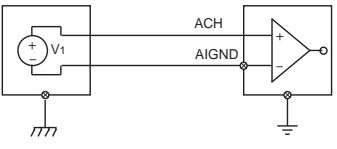
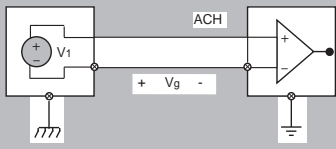
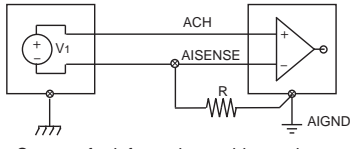
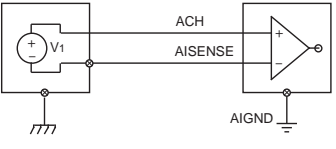
Input	Signal Source Type	
	Floating Signal Source (Not Connected to Building Ground)	Grounded Signal Source
	Examples <ul style="list-style-type: none"> • Ungrounded Thermocouples • Signal conditioning with isolated outputs • Battery devices 	Examples <ul style="list-style-type: none"> • Plug-in instruments with nonisolated outputs
Differential (DIFF)	 <p>See text for information on bias resistors.</p>	
Single-Ended — Ground Referenced (RSE)		<p>NOT RECOMMENDED</p>  <p>Ground-loop losses, V_g, are added to measured signal</p>
Single-Ended — Nonreferenced (NRSE)	 <p>See text for information on bias resistors.</p>	

Differential Connection Considerations (DIFF Configuration)

Differential connections are those in which each PCI-1200 analog input signal has its own reference signal or signal return path. These connections are available when you configure the PCI-1200 in the DIFF mode. Each input signal is tied to the positive input of the instrumentation amplifier, and its reference signal, or return, is tied to the negative input of the instrumentation amplifier.

When configuring the PCI-1200 for DIFF input, each signal uses two of the multiplexer inputs—one for the signal and one for its reference signal. Therefore, only four analog input channels are available when using the DIFF configuration. Use the DIFF input configuration when any of the following conditions is present:

- Input signals are low level (less than 1 V).
- Leads connecting the signals to the PCI-1200 are greater than 10 ft.
- Any of the input signals require a separate ground-reference point or return signal.
- The signal leads travel through noisy environments.

Differential signal connections reduce picked-up noise and increase common-mode signal and noise rejection. With these connections, input signals can float within the common-mode limits of the input instrumentation amplifier.

Differential Connections for Grounded Signal Sources

Figure 3-3 shows how to connect a ground-referenced signal source to a PCI-1200 board configured for DIFF input. Configuration instructions are in the *Analog I/O Configuration* section in Chapter 2, *Installation and Configuration*.

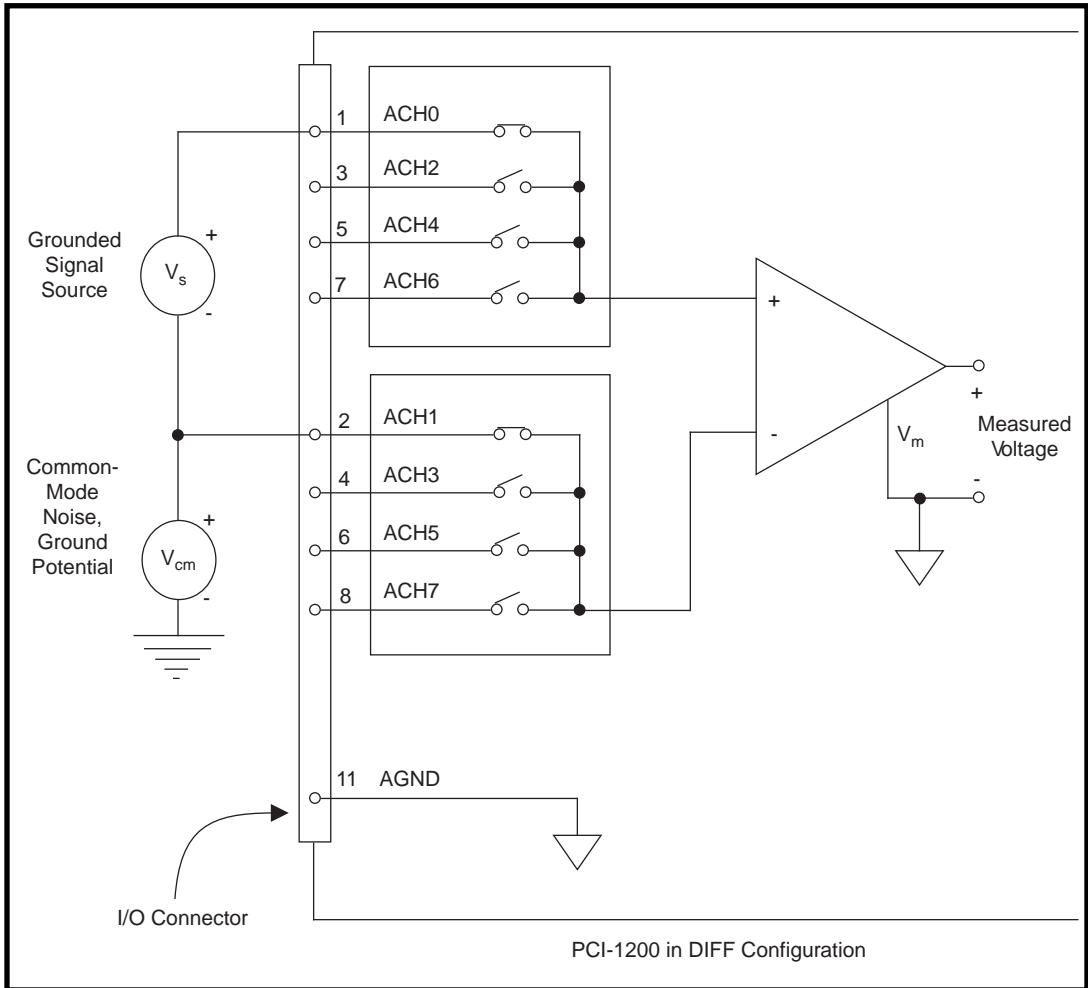

Figure 3-3. Differential Input Connections for Grounded Signal Sources

With this type of connection, the instrumentation amplifier rejects both the common-mode noise in the signal and the ground-potential difference between the signal source and the PCI-1200 ground (shown as V_{cm} in Figure 3-3).

Differential Connections for Floating Signal Sources

Figure 3-4 shows how to connect a floating signal source to a PCI-1200 board configured for DIFF input. Configuration instructions are in the

Analog I/O Configuration section of Chapter 2, *Installation and Configuration*.

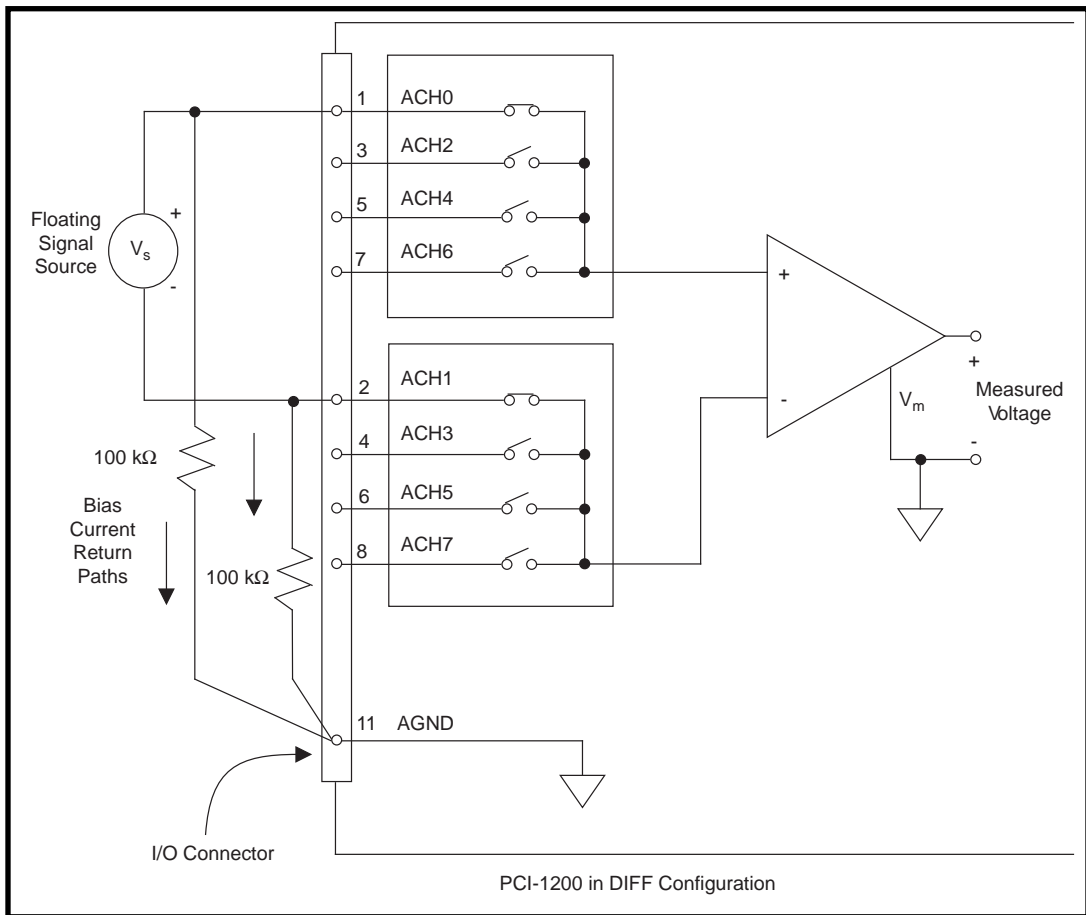

Figure 3-4. Differential Input Connections for Floating Sources

The $100\text{ k}\Omega$ resistors shown in Figure 3-4 create a return path to ground for the bias currents of the instrumentation amplifier. If there is no return path, the instrumentation amplifier bias currents charge stray capacitances, resulting in uncontrollable drift and possible saturation in the amplifier. Typically, values from $10\text{ k}\Omega$ to $100\text{ k}\Omega$ are used.

A resistor from each input to ground, as shown in Figure 3-4, provides bias current return paths for an AC-coupled input signal.

If the input signal is DC-coupled, you need only the resistor that connects the negative signal input to ground. This connection does not lower the input impedance of the analog input channel.

Single-Ended Connection Considerations

Single-ended connections are those in which all PCI-1200 analog input signals are referenced to one common ground. The input signals are tied to the positive input of the instrumentation amplifier, and their common ground point is tied to the negative input of the instrumentation amplifier.

When the PCI-1200 is configured for single-ended input (NRSE or RSE), eight analog input channels are available. Use single-ended input connections when the following conditions are met by all input signals:

- Input signals are high level (greater than 1 V).
- Leads connecting the signals to the PCI-1200 are less than 10 ft.
- All input signals share a common reference signal (at the source).

If any of the preceding criteria is not met, use the DIFF input configuration.

You can software configure the PCI-1200 for two different types of single-ended connections, RSE configuration and NRSE configuration. Use the RSE configuration for floating signal sources; in this case, the PCI-1200 provides the reference ground point for the external signal. Use the NRSE configuration for ground-referenced signal sources; in this case, the external signal supplies its own reference ground point and the PCI-1200 should not supply one.

Single-Ended Connections for Floating Signal Sources (RSE Configuration)

Figure 3-5 shows how to connect a floating signal source to a PCI-1200 board configured for RSE mode. Configure the PCI-1200 analog input circuitry for RSE input to make these types of connections. Configuration instructions are in the *Analog I/O Configuration* section of Chapter 2, *Installation and Configuration*.

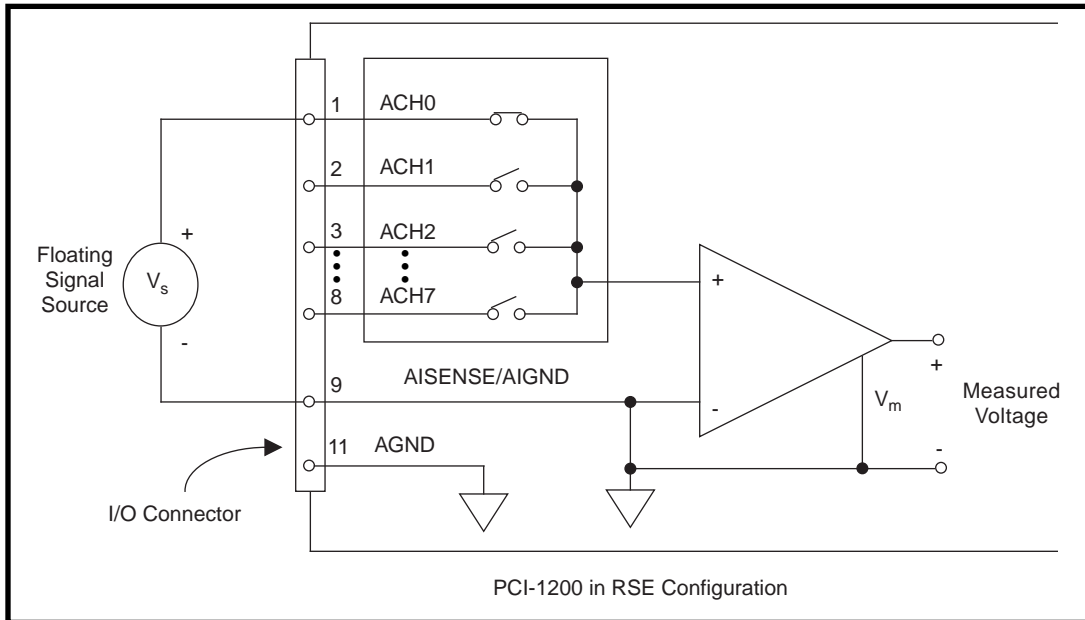

Figure 3-5. Single-Ended Input Connections for Floating Signal Sources

Single-Ended Connections for Grounded Signal Sources (NRSE Configuration)

If you measure a grounded signal source with a single-ended configuration, configure the PCI-1200 in the NRSE input configuration. The signal is connected to the positive input of the PCI-1200 instrumentation amplifier and the signal local ground reference is connected to the negative input of the PCI-1200 instrumentation amplifier. Therefore, connect the ground point of the signal to the AISENSE pin. Any potential difference between the PCI-1200 ground and the signal ground appears as a common-mode signal at both the positive and negative inputs of the instrumentation amplifier and is therefore rejected by the amplifier. On the other hand, if the input circuitry of the PCI-1200 is referenced to ground, such as in the RSE configuration, this difference in ground potentials appears as an error in the measured voltage.

Figure 3-6 shows how to connect a grounded signal source to a PCI-1200 board configured in the NRSE configuration. Configuration instructions are included in the *Analog I/O Configuration* section in Chapter 2, *Installation and Configuration*.

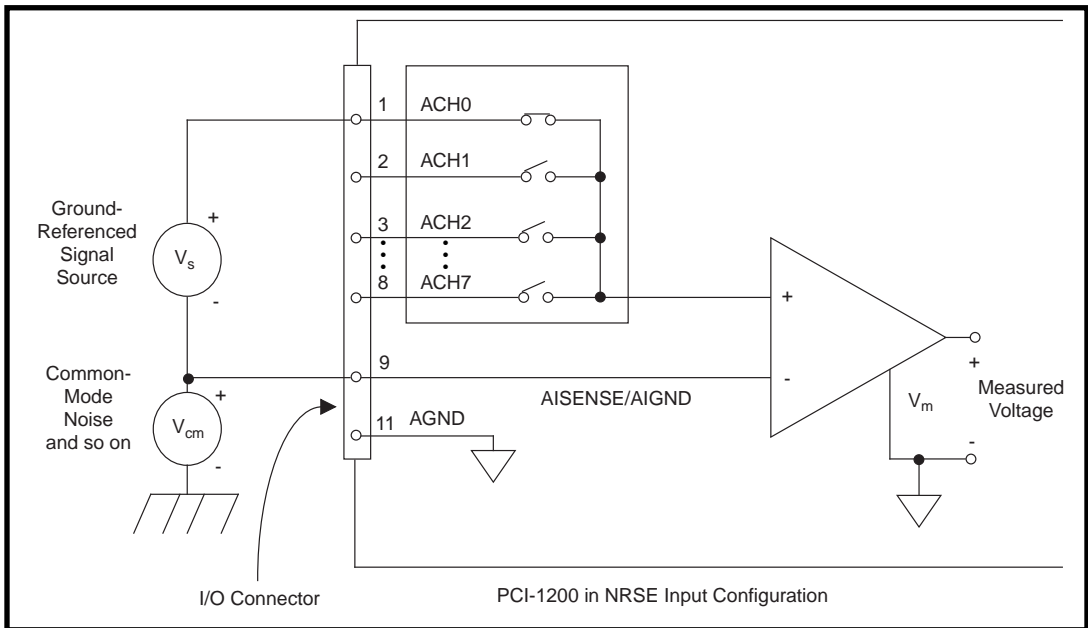

Figure 3-6. Single-Ended Input Connections for Grounded Signal Sources

Common-Mode Signal Rejection Considerations

Figures 3-4 and 3-6 show connections for signal sources that are already referenced to some ground point with respect to the PCI-1200. In these cases, the instrumentation amplifier can reject any voltage caused by ground-potential differences between the signal source and the PCI-1200. In addition, with differential input connections, the instrumentation amplifier can reject common-mode noise pickup in the leads connecting the signal sources to the PCI-1200.

The common-mode input range of the PCI-1200 instrumentation amplifier is the magnitude of the greatest common-mode signal that can be rejected.

The common-mode input range for the PCI-1200 depends on the size of the differential input signal ($V_{\text{diff}} = V_{\text{in}^+} - V_{\text{in}^-}$) and the gain setting of the instrumentation amplifier. In unipolar mode, the differential input range is 0 to 10 V. In bipolar mode, the differential input range is -5 to +5 V. Inputs should remain within a range of -5 to 10 V in both bipolar and unipolar modes.

Analog Output Signal Connections

Pins 10 through 12 on the I/O connector are analog output signal pins.

Pins 10 and 12 are the DAC0OUT and DAC1OUT signal pins. DAC0OUT is the voltage output signal for analog output channel 0. DAC1OUT is the voltage output signal for analog output channel 1.

Pin 11, AGND, is the ground-reference point for both analog output channels as well as analog input.

The following output ranges are available:

- Output signal range
 - Bipolar output $\pm 5\text{ V}^*$
 - Unipolar output 0 to 10 V*

*Maximum load current $\pm 2\text{ mA}$ for 12-bit linearity.

Figure 3-7 shows how to make analog output signal connections.

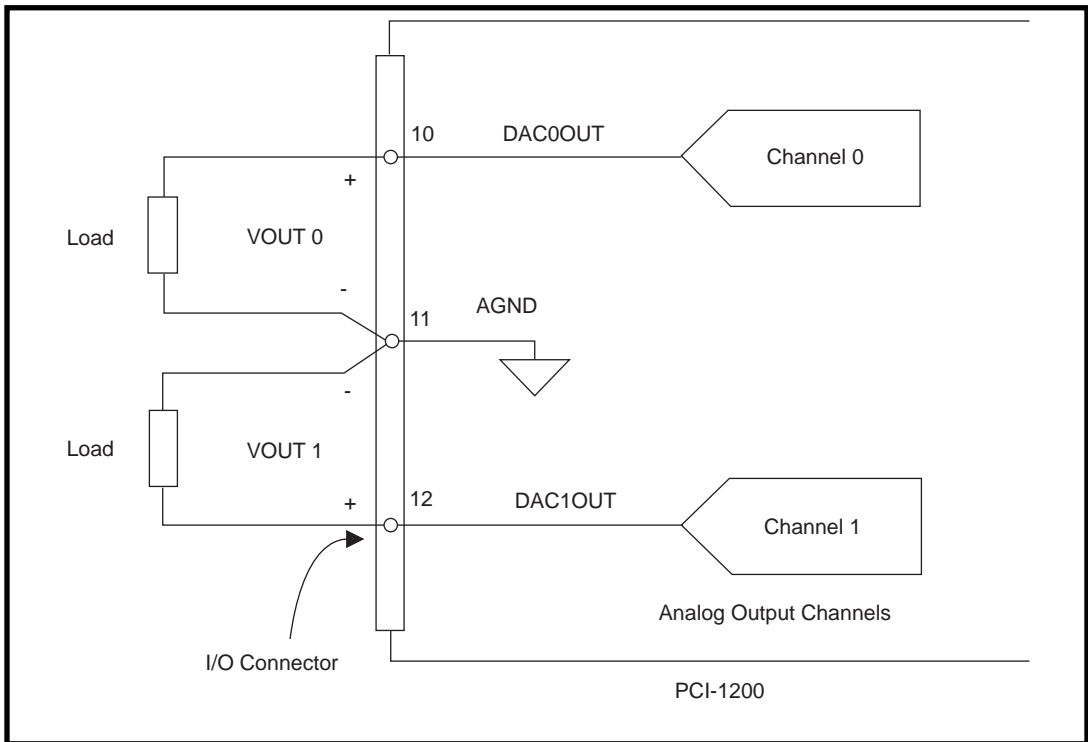

Figure 3-7. Analog Output Signal Connections

Digital I/O Signal Connections

Pins 13 through 37 of the I/O connector are digital I/O signal pins. Digital I/O on the PCI-1200 uses the 82C55A integrated circuit. The 82C55A is a general purpose peripheral interface containing 24 programmable I/O pins. These pins represent the three 8-bit ports (PA, PB, and PC) of the 82C55A.

Pins 14 through 21 are connected to the digital lines PA<7..0> for digital I/O port A. Pins 22 through 29 are connected to the digital lines PB<7..0> for digital I/O port B. Pins 30 through 37 are connected to the digital lines PC<7..0> for digital I/O port C. Pin 13, DGND, is the digital ground pin for all three digital I/O ports. Refer to Appendix A, *Specifications*, for signal voltage and current specifications.

The following specifications and ratings apply to the digital I/O lines. All voltages are with respect to DGND.

Logical Inputs and Outputs

- Absolute max voltage rating -0.5 to +5.5 V with respect to DGND
- Digital I/O lines:

– Input logic low voltage	-0.3 V min	0.8 V max
– Input logic high voltage	2.2 V min	5.3 V max
– Output logic low voltage (at output current = 2.5 mA)	—	0.4 V max
– Output logic high voltage (at output current = -2.5 mA)	3.7 V min	—
– Input leakage current ($0 < V_{in} < 5$ V)	-1 μ A min	1 μ A max

Figure 3-8 illustrates signal connections for three typical digital I/O applications.

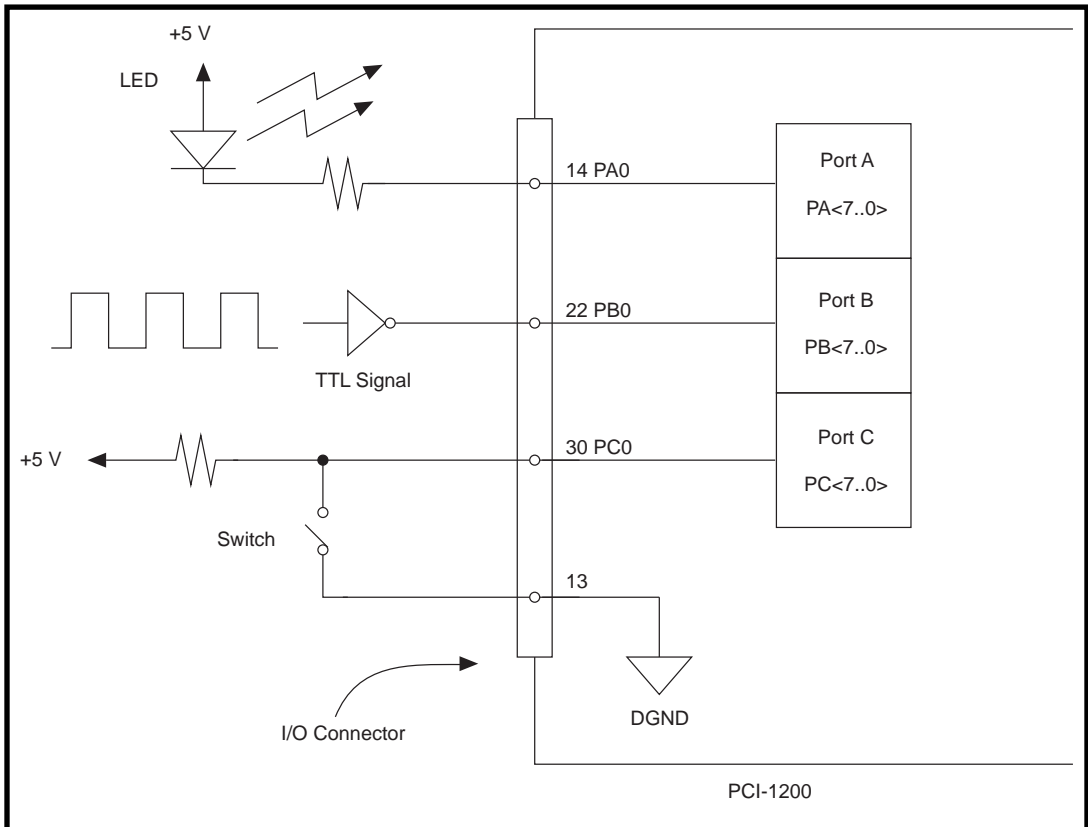

Figure 3-8. Digital I/O Connections

In Figure 3-8, port A is configured for digital output, and ports B and C are configured for digital input. Digital input applications include receiving TTL signals and sensing external device states such as the switch in Figure 3-8. Digital output applications include sending TTL signals and driving external devices such as the LED shown in Figure 3-8.

Port C Pin Connections

The signals assigned to port C depend on the mode in which the 82C55A is programmed. In mode 0, port C is considered to be two 4-bit I/O ports. In modes 1 and 2, port C is used for status and handshaking signals with two or three I/O bits mixed in. Table 3-5 summarizes the

signal assignments of port C for each programmable mode. Refer to the *PCI-1200 Register-Level Programmer Manual* for register-level programming information.

Table 3-5. Port C Signal Assignments

Programmable Mode	Group A					Group B		
	PC7	PC6	PC5	PC4	PC3	PC2	PC1	PC0
Mode 0	I/O	I/O	I/O	I/O	I/O	I/O	I/O	I/O
Mode 1 Input	I/O	I/O	IBF _A	STB _A *	INTR _A	STB _B *	IBFB _B	INTR _B
Mode 1 Output	OBF _A *	ACK _A *	I/O	I/O	INTR _A	ACK _B *	OBF _B *	INTR _B
Mode 2	OBF _A *	ACK _A *	IBF _A	STB _A *	INTR _A	I/O	I/O	I/O

*Indicates that the signal is active low.

Timing Specifications

Use the handshaking lines STB* and IBF to synchronize input transfers. Use the handshaking lines OBF* and ACK* to synchronize output transfers.

The following signals are used in the timing diagrams shown later in this chapter:

Table 3-6. Signal Names Used in Timing Diagrams

Name	Type	Description
STB*	Input	Strobe Input—A low signal on this handshaking line loads data into the input latch.
IBF	Output	Input Buffer Full—A high signal on this handshaking line indicates that data has been loaded into the input latch. This is primarily an input acknowledge signal.
ACK*	Input	Acknowledge Input—A low signal on this handshaking line indicates that the data written from the specified port has been accepted. This signal is primarily a response from the external device that it has received the data from the PCI-1200.

Table 3-6. Signal Names Used in Timing Diagrams (Continued)

Name	Type	Description
OBF*	Output	Output Buffer Full—A low signal on this handshaking line indicates that data has been written from the specified port.
INTR	Output	Interrupt Request—This signal becomes high when the 82C55A is requesting service during a data transfer. Set the appropriate interrupt enable signals to generate this signal.
RD*	Internal	Read Signal—This signal is the read signal generated from the PCI interface circuitry.
WRT*	Internal	Write Signal—This signal is the write signal generated from the PCI interface circuitry.
DATA	Bidirectional	Data Lines at the Specified Port—This signal indicates when the data on the data lines at a specified port is or should be available.

Mode 1 Input Timing

The timing specifications for an input transfer in mode 1 are as follows:

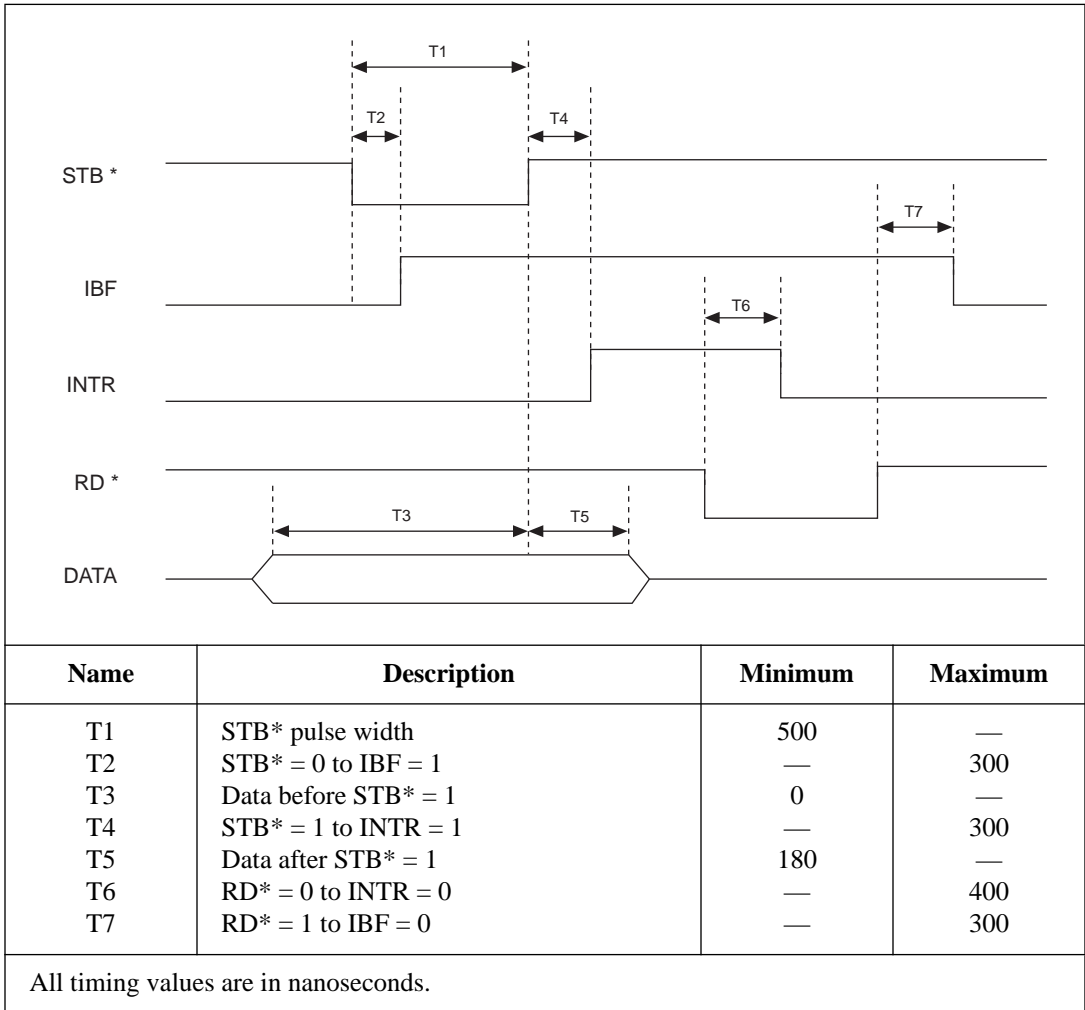

Figure 3-9. Mode 1 Timing Specifications for Input Transfers

Mode 1 Output Timing

The timing specifications for an output transfer in mode 1 are as follows:

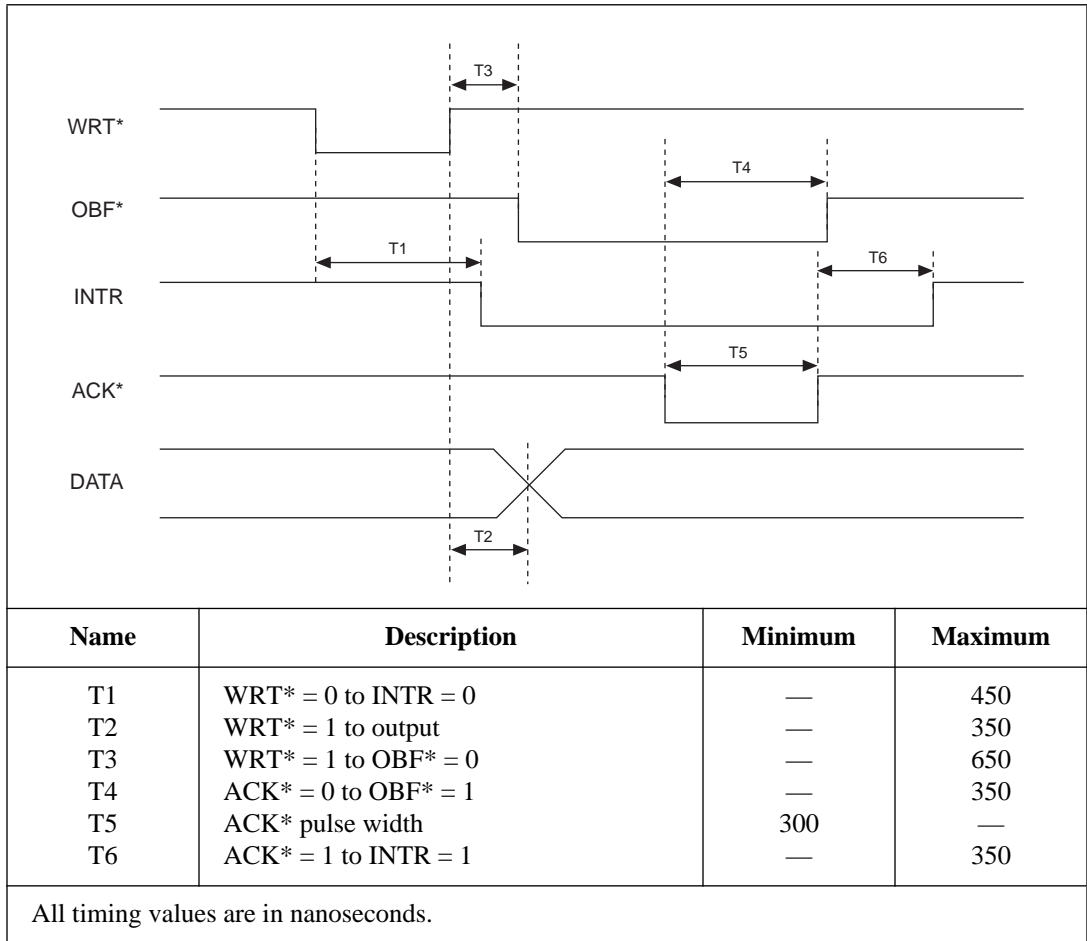

Figure 3-10. Mode 1 Timing Specifications for Output Transfers

Mode 2 Bidirectional Timing

The timing specifications for bidirectional transfers in mode 2 are as follows:

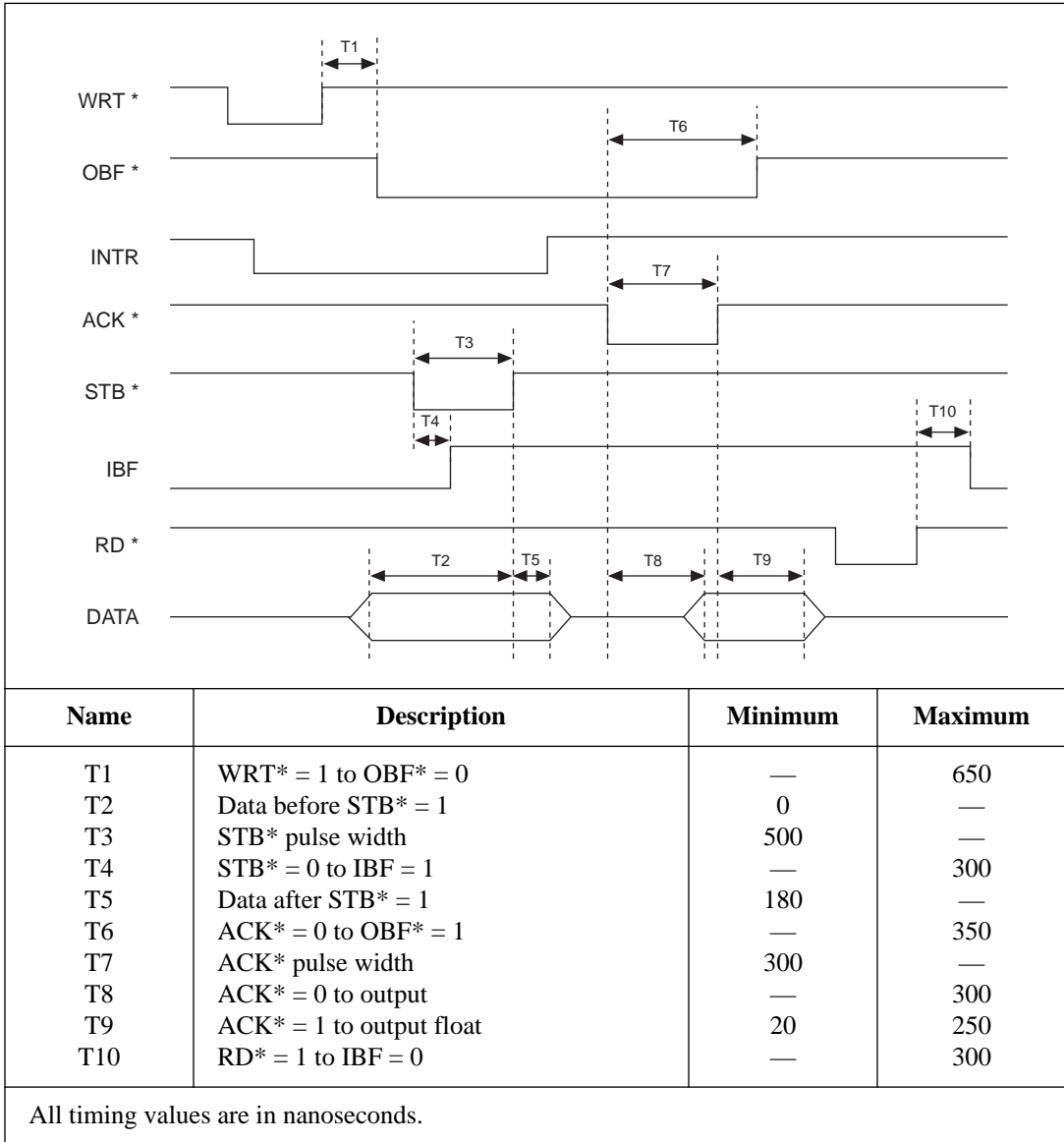

Figure 3-11. Mode 2 Timing Specifications for Bidirectional Transfers

DAQ and General Purpose Timing Signal Connections

Pins 38 through 48 of the I/O connector are connections for timing I/O signals. The PCI-1200 timing I/O uses two 82C53 counter/timer integrated circuits. One circuit, designated 82C53(A), is used exclusively for DAQ timing, and the other, 82C53(B), is available for general use. Use pins 38 through 40 and pin 43 to carry external signals for DAQ timing. These signals are explained in the next section, *DAQ Timing Connections*. Pins 41 through 48 carry general purpose timing signals from 82C53(B). These signals are explained in the *General Purpose Timing Signal Connections* section later in this chapter.

DAQ Timing Connections

Each 82C53 counter/timer circuit contains three counters. Counter 0 on the 82C53(A) counter/timer, referred to as A0, is a sample-interval counter in timed A/D conversions. Counter 1 on the 82C53(A) counter/timer, referred to as A1, is a sample counter in controlled A/D conversions. Therefore, counter A1 stops data acquisition after a predefined number of samples. These counters are not available for general use.

Instead of counter A0, you can use EXTCONV* to externally time conversions. Figure 3-12 shows the timing requirements for the EXTCONV* input. An A/D conversion is initiated by a falling edge on the EXTCONV*.

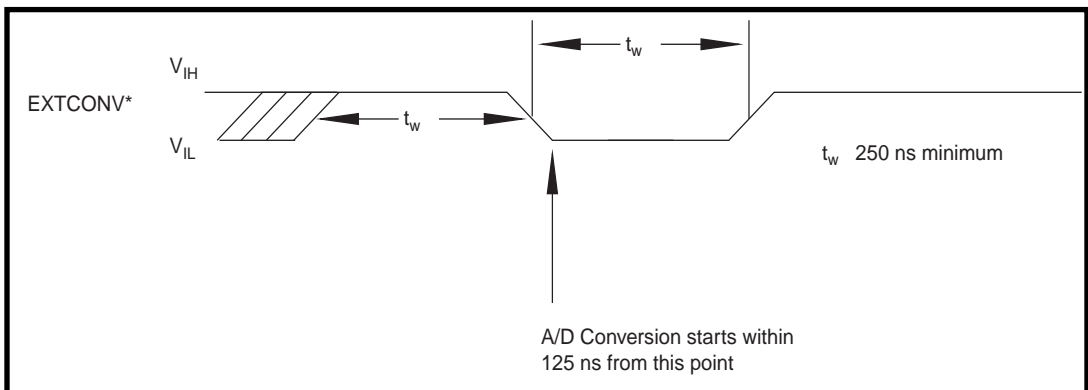

Figure 3-12. EXTCONV* Signal Timing

The external control signal EXTTRIG can either start a DAQ sequence or terminate an ongoing DAQ sequence depending on the mode—posttrigger (POSTTRIG) or pretrigger (PRETRIG). These modes are software selectable.

In the POSTTRIG mode, EXTTRIG serves as an external trigger that initiates a DAQ sequence. When you use counter A0 to time sample intervals, a rising edge on EXTTRIG starts counter A0 and the DAQ sequence. When you use EXTCONV* to time sample intervals, data acquisition is enabled on a rising edge of EXTTRIG followed by a rising edge on EXTCONV*. The first conversion occurs on the next falling edge of EXTCONV*. Further transitions on the EXTTRIG line have no effect until a new DAQ sequence is established.

Figure 3-13 shows a possible controlled DAQ sequence using EXTCONV* and EXTTRIG. The rising edge of EXTCONV* that enables external conversions must occur a minimum of 50 ns after the rising edge of EXTTRIG. The first conversion occurs on the next falling edge of EXTCONV*.

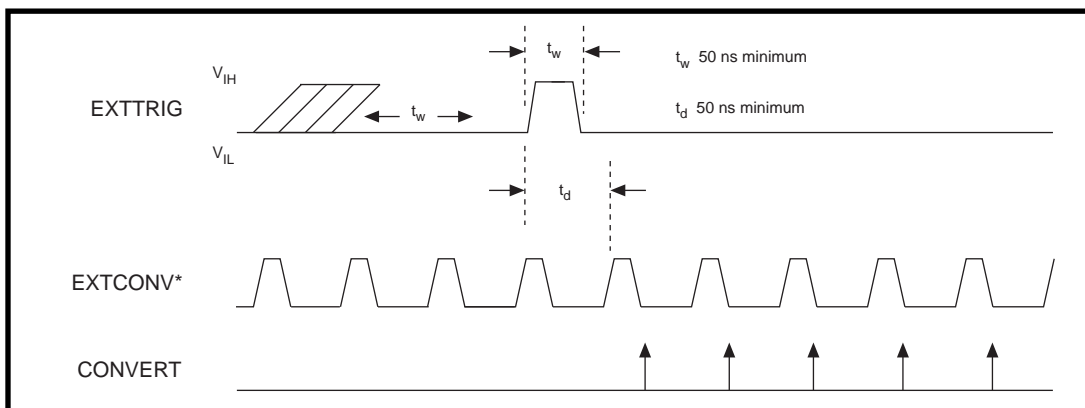

Figure 3-13. Posttrigger DAQ Timing

In the PRETRIG mode, EXTTRIG serves as a pretrigger signal. Data is acquired both before and after the EXTTRIG signal occurs. A/D conversions are software enabled, which initiates the DAQ operation. However, the sample counter is not started until the EXTTRIG input senses a rising edge. Conversions remain enabled until the sample counter counts to zero. The maximum number of samples acquired after the stop trigger is limited to 65,535. The number of samples acquired before the trigger is limited only by the size of the memory buffer available for data acquisition.

Figure 3-14 shows a pretrigger DAQ timing sequence using EXTTRIG and EXTCONV*. The DAQ operation has been initiated through software. Notice that the sample counter has been programmed to allow five conversions after the rising edge on the EXTTRIG signal. Additional transitions on the EXTTRIG line have no effect until you initiate a new DAQ sequence.

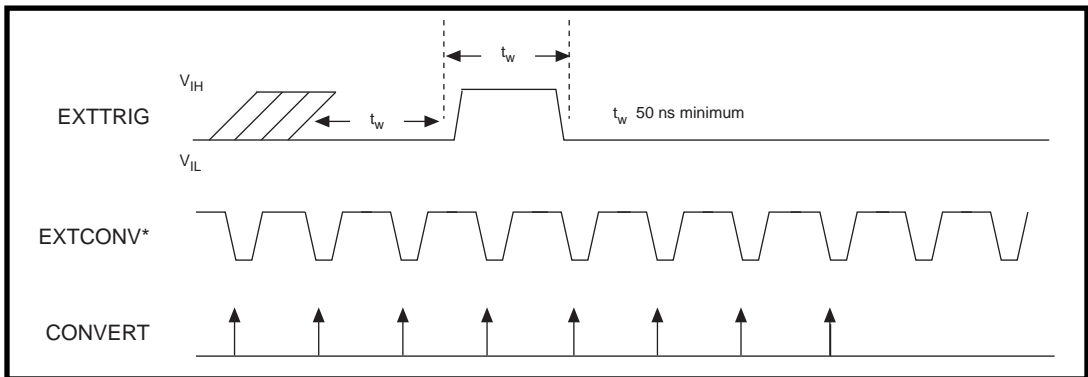

Figure 3-14. Pretrigger DAQ Timing

For interval scanning data acquisition, counter B1 determines the scan interval. Instead of using counter B1, you can externally time the scan interval through OUTB1. If you externally time the sample interval, we recommend that you also externally time the scan interval.

Figure 3-15 shows an example of an interval scanning DAQ operation. The scan interval and the sample interval are being timed externally through OUTB1 and EXTCONV*. Channels 1 and 0 of the input multiplexers are scanned once during each scan interval. The first rising edge of EXTCONV* must occur a minimum of 50 ns after the rising edge on OUTB1. The first rising edge of EXTCONV* after the rising edge of OUTB1 enables an internal GATE signal that allows conversions to occur. The first conversion then occurs on the following falling edge of EXTCONV*. The GATE signal disables conversions for the rest of the scan interval after the desired channels have been scanned. Refer to the *Interval Scanning Acquisition Mode* section in Chapter 4, *Theory of Operation*, for more information on interval scanning.

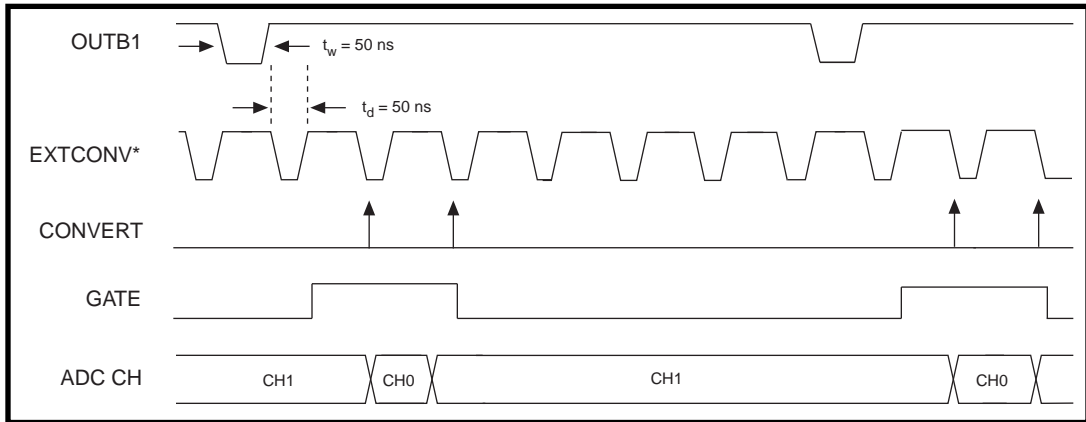

Figure 3-15. Interval-Scanning Signal Timing

You use the final external control signal, EXTUPDATE*, to externally control updating the output voltage of the 12-bit DACs and/or to generate an externally timed interrupt. There are two update modes, immediate update and delayed update. In immediate update mode the analog output is updated as soon as a value is written to the DAC. If you select the delayed update mode, a value is written to the DAC; however, the corresponding DAC voltage is not updated until a low level on the EXTUPDATE* signal is sensed. Furthermore, if you enable interrupt generation, an interrupt is generated whenever a rising edge is detected on the EXTUPDATE* bit. Therefore, you can perform externally timed, interrupt-driven waveform generation on the PCI-1200. The EXTUPDATE* line is susceptible to noise caused by switching lines and could generate false interrupts. We recommend that the width of the EXTUPDATE* pulse be as short as possible, but greater than 50 ns.

Figure 3-16 illustrates a waveform generation timing sequence using the EXTUPDATE* signal and the delayed update mode. The DACs are updated by a high level on the DAC OUTPUT UPDATE signal, which in this case is triggered by a low level on the EXTUPDATE* line. CNTINT is the signal that interrupts the computer. This interrupt is generated on the rising edge of EXTUPDATE*. DACWRT is the signal that writes a new value to the DAC.

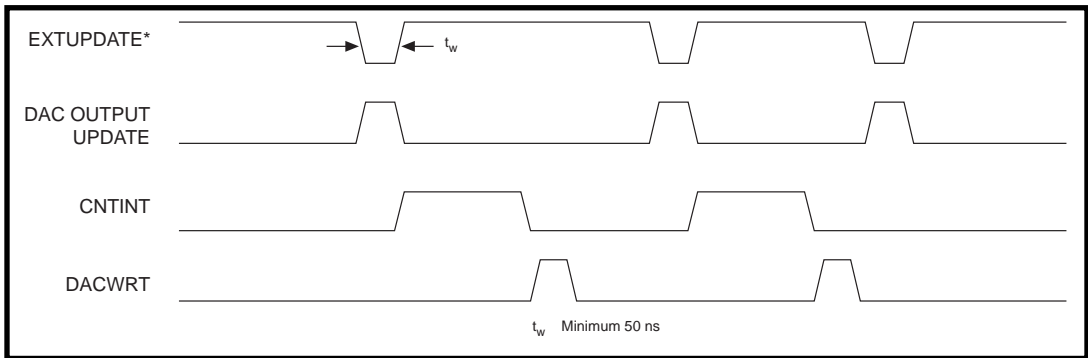

Figure 3-16. EXTUPDATE* Signal Timing for Updating DAC Output

The following rating applies to the EXTCONV*, EXTTRIG, OUTB1, and EXTUPDATE* signals.

- Absolute max voltage -0.5 to 5.5 V with
input rating respect to DGND

For more information concerning the various modes of data acquisition and analog output, refer to your NI-DAQ documentation or to Chapter 4, *Theory of Operation*, in this manual.

General Purpose Timing Signal Connections

The general purpose timing signals include the GATE, CLK, and OUT signals for the three 82C53(B) counters. The 82C53 counter/timers can be used for general purpose applications such as pulse and square wave generation, event counting, and pulse-width, time-lapse, and frequency measurement. For these applications, the CLK and GATE signals at the I/O connector control the counters. The single exception is counter B0, which has an internal 2 MHz clock.

To perform pulse and square wave generation, program a counter to generate a timing signal at its OUT output pin. To perform event counting, program a counter to count rising or falling edges applied to any of the 82C53 CLK inputs, then read the counter value to determine the number of edges that have occurred. You can enable or disable the counting operation by controlling the gate input. Figure 3-17 shows connections for a typical event-counting operation in which a switch is used to gate the counter on and off.

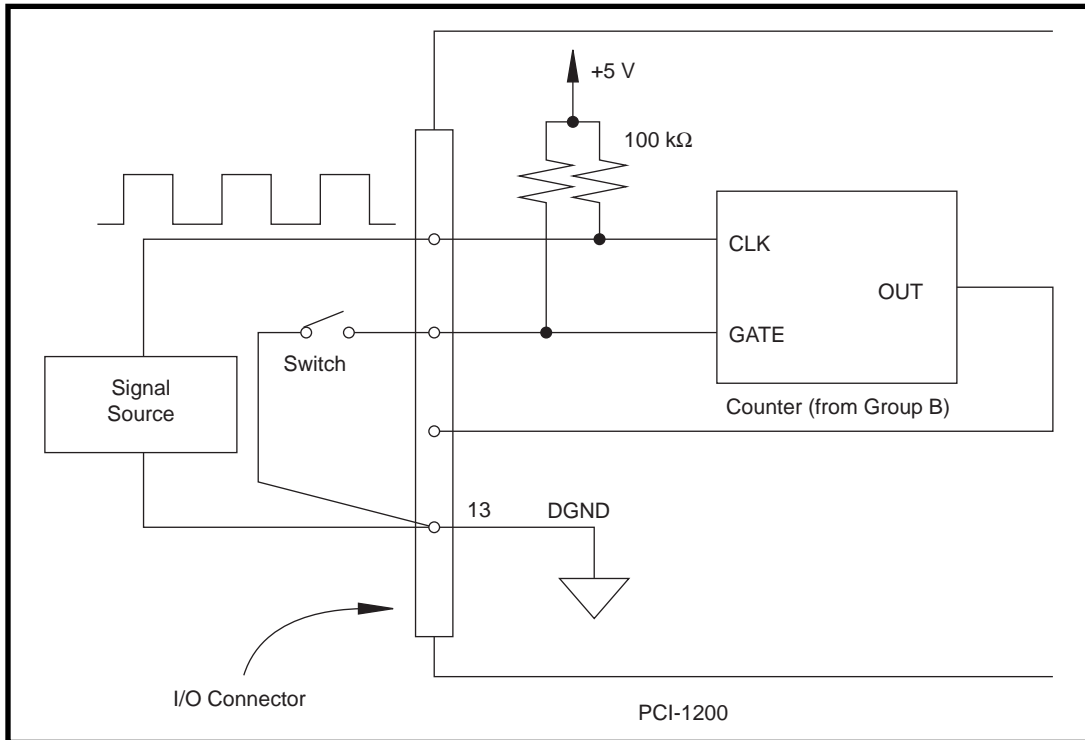

Figure 3-17. Event-Counting Application with External Switch Gating

Pulse-width measurement is performed by level gating. The pulse you want to measure is applied to the counter GATE input. The counter is loaded with the known count and is programmed to count down while the signal at the GATE input is high. The pulse width equals the counter difference (loaded value minus read value) multiplied by the CLK period.

Perform time-lapse measurement by programming a counter to be edge gated. An edge is applied to the counter GATE input to start the counter. Program the counter to start counting after receiving a low-to-high edge. The time lapse since receiving the edge equals the counter value difference (loaded value minus read value) multiplied by the CLK period.

To perform frequency measurement, program a counter to be level gated and count the number of falling edges in a signal applied to a CLK input. The gate signal applied to the counter GATE input is of known duration. In this case, program the counter to count falling edges at the

CLK input while the gate is applied. The frequency of the input signal then equals the count value divided by the gate period. Figure 3-18 shows the connections for a frequency measurement application. You can also use a second counter to generate the gate signal in this application. If you use a second counter, however, you must externally invert the signal.

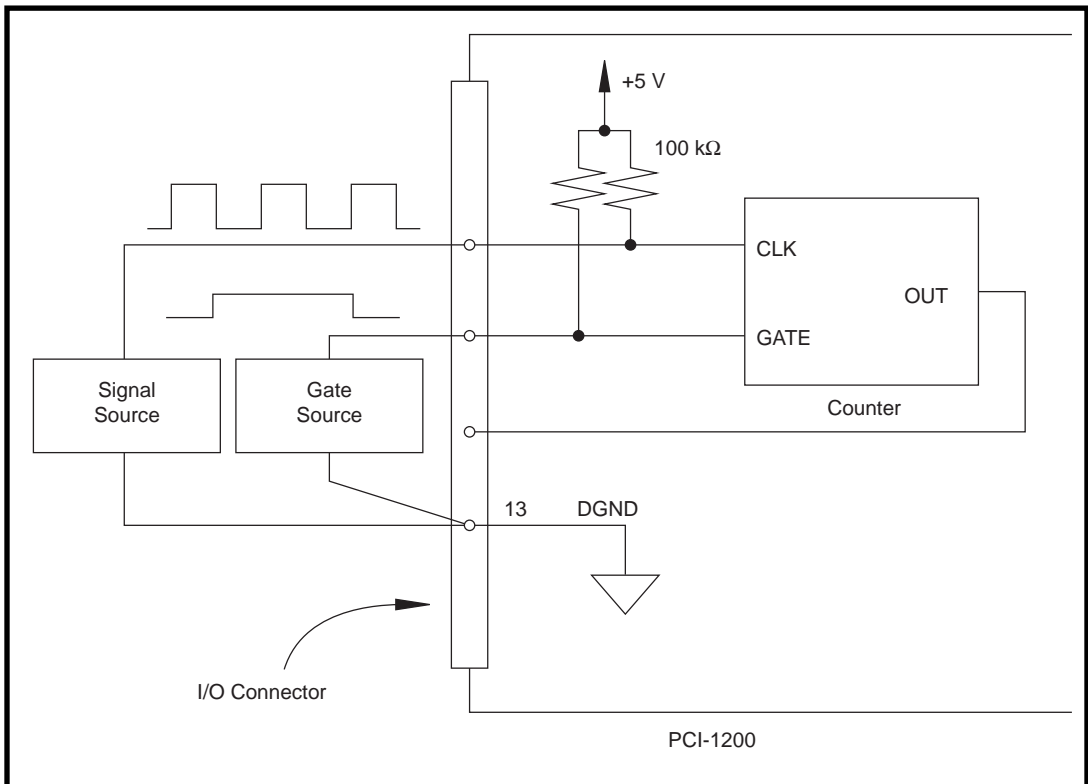

Figure 3-18. Frequency Measurement Application

The GATE, CLK, and OUT signals for counters B1 and B2 are available at the I/O connector. The GATE and CLK pins are internally pulled up to +5 V through a 100 kΩ resistor. Refer to Appendix A, *Specifications*, for signal voltage and current specifications.

The following specifications and ratings apply to the 82C53 I/O signals:

- Absolute max voltage input rating -0.5 to +5.5 V with respect to DGND
- 82C53 digital input specifications (referenced to DGND):
 - V_{IH} input logic high voltage 2.2 V min 5.3 V max
 - V_{IL} input logic low voltage -0.3 V min 0.8 V max
 - Input load current -10 μ A min +10 μ A max
- 82C53 digital output specifications (referenced to DGND):
 - V_{OH} output logic high voltage 3.7 V min —
 - V_{OL} output logic low voltage — 0.45 V max
 - I_{OH} output source current, at V_{OH} — -0.92 mA max
 - I_{OL} output sink current, at V_{OL} — 2.1 mA max

Figure 3-19 shows the timing requirements for the GATE and CLK input signals and the timing specifications for the 82C53 OUT output signals.

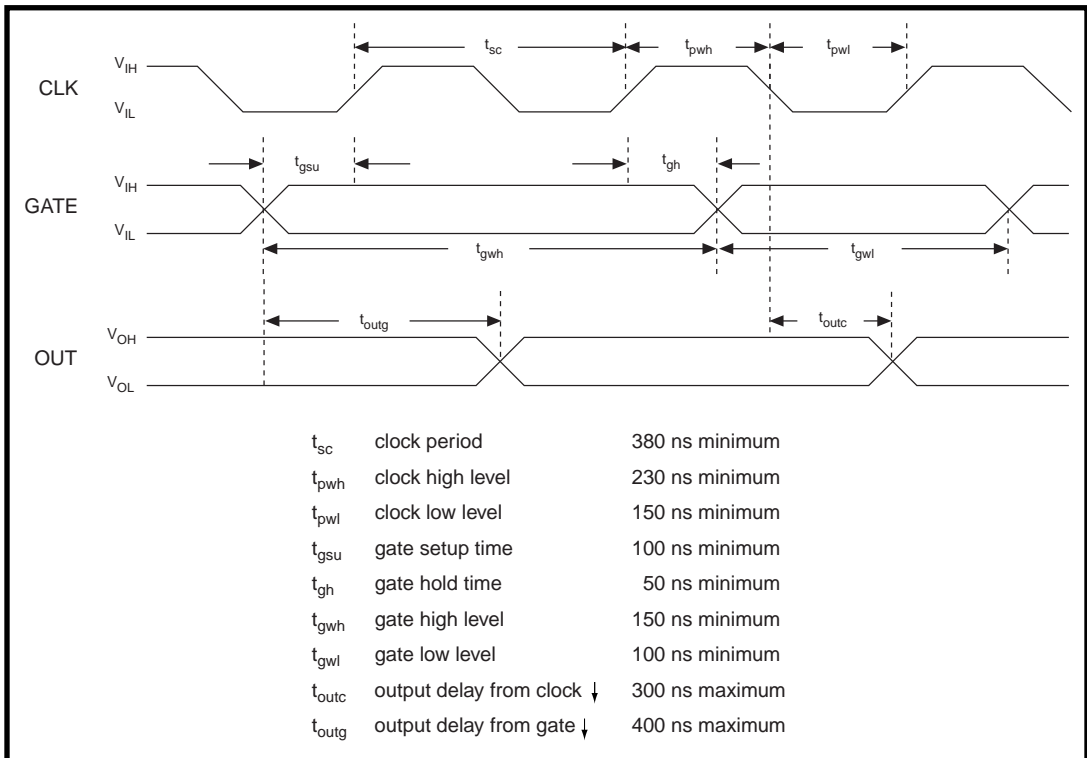

Figure 3-19. General Purpose Timing Signals

The GATE and OUT signals in Figure 3-19 are referenced to the rising edge of the CLK signal.

Power Connections

Pin 49 of the I/O connector supplies +5 V from the computer's power supply via a self-resetting fuse. The fuse will reset automatically within a few seconds after the overcurrent condition is removed. Pin 49 is referenced to DGND and you can use the +5 V to power external digital circuitry.

- Power rating 1 A at +4.65 to +5.25 V



Warning: *Do not directly connect this +5 V power pin to analog or digital ground or to any other voltage source on the PCI-1200 or any other device. Doing so can damage the PCI-1200 or your computer. National Instruments is NOT liable for any damage due to incorrect power connections.*

Theory of Operation

This chapter explains the operation of each functional unit of the PCI-1200.

Functional Overview

The block diagram in Figure 4-1 shows a functional overview of the PCI-1200 board.

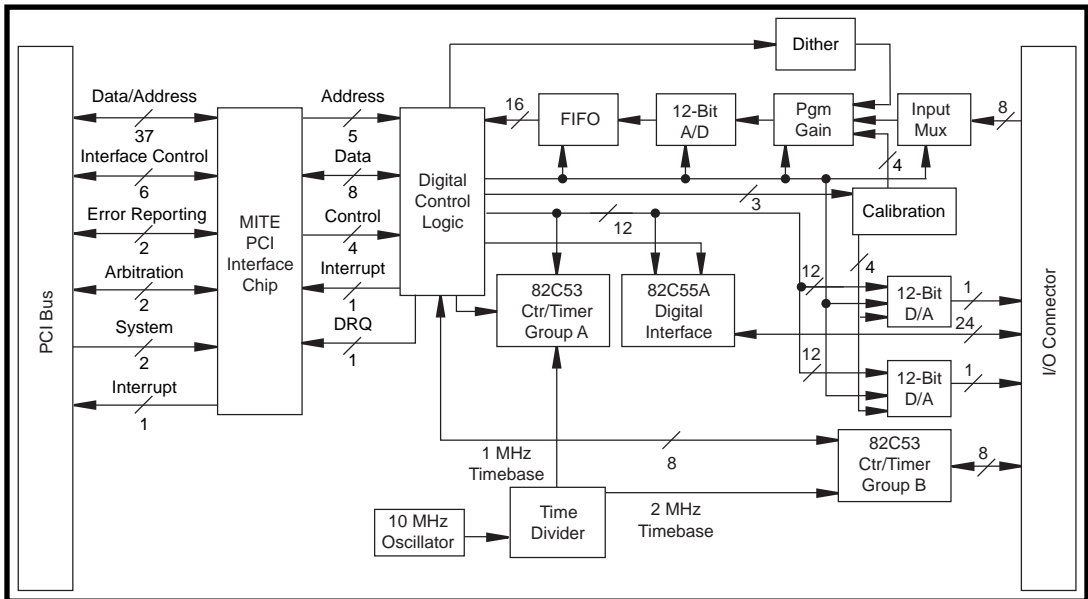

Figure 4-1. PCI-1200 Block Diagram

The major components of the PCI-1200 are as follows:

- MITE PCI interface circuitry
- Timing circuitry
- Analog input circuitry
- Analog output circuitry

- Digital I/O circuitry
- Calibration circuitry

The internal data and control buses interconnect the components. The rest of this chapter explains the theory of operation of each of the PCI-1200 components. Calibration circuitry is discussed in Chapter 5, *Calibration*.

PCI Interface Circuitry

The PCI-1200 interface circuitry consists of the MITE PCI interface chip and a digital control logic chip. The MITE PCI interface chip provides a mechanism for the PCI-1200 to communicate with the PCI bus. It is an Application Specific Integrated Circuit (ASIC) designed by National Instruments specifically for data acquisition. The digital control logic chip connects the MITE PCI interface chip with the rest of the board. The PCI-1200 is fully compliant with *PCI Local Bus Specification*, Revision 2.0. Therefore, the base memory address and interrupt level for the board are stored inside the MITE PCI interface chip at power on. You do not need to set any switches or jumpers. The PCI bus is capable of 8-bit, 16-bit, or 32-bit transfers, but the PCI-1200 uses only 8-bit transfers.

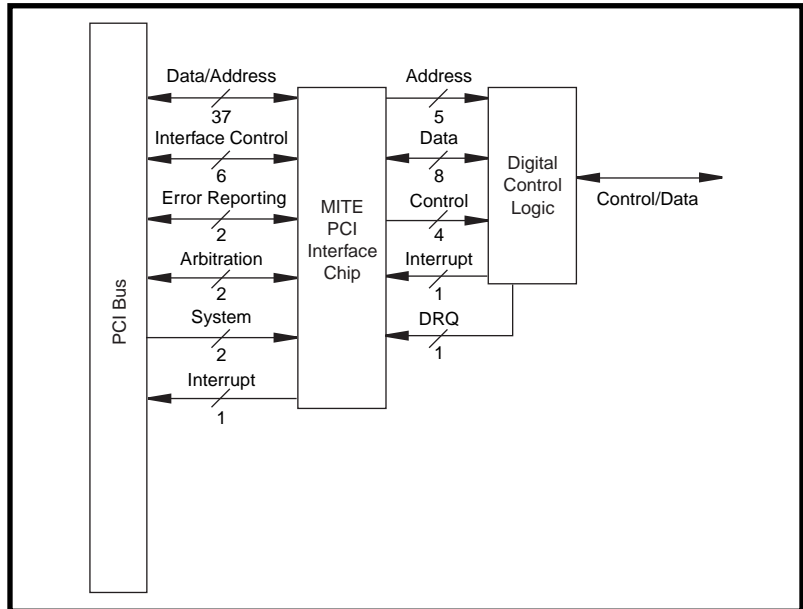

Figure 4-2. PCI Interface Circuitry

The PCI-1200 generates an interrupt in the following five cases (each of these interrupts is individually enabled and cleared):

- When a single A/D conversion can be read from the A/D FIFO memory.
- When the A/D FIFO is half-full.
- When a DAQ operation completes, including when either an OVERFLOW or an OVERRUN error occurs.
- When the digital I/O circuitry generates an interrupt.
- When a rising edge signal is detected on the DAC update signal.

Timing

The PCI-1200 uses two 82C53 counter/timer integrated circuits for internal DAQ and DAC timing and for general purpose I/O timing functions. Figure 4-3 shows a block diagram of both groups of timing circuitry (counter groups A and B).

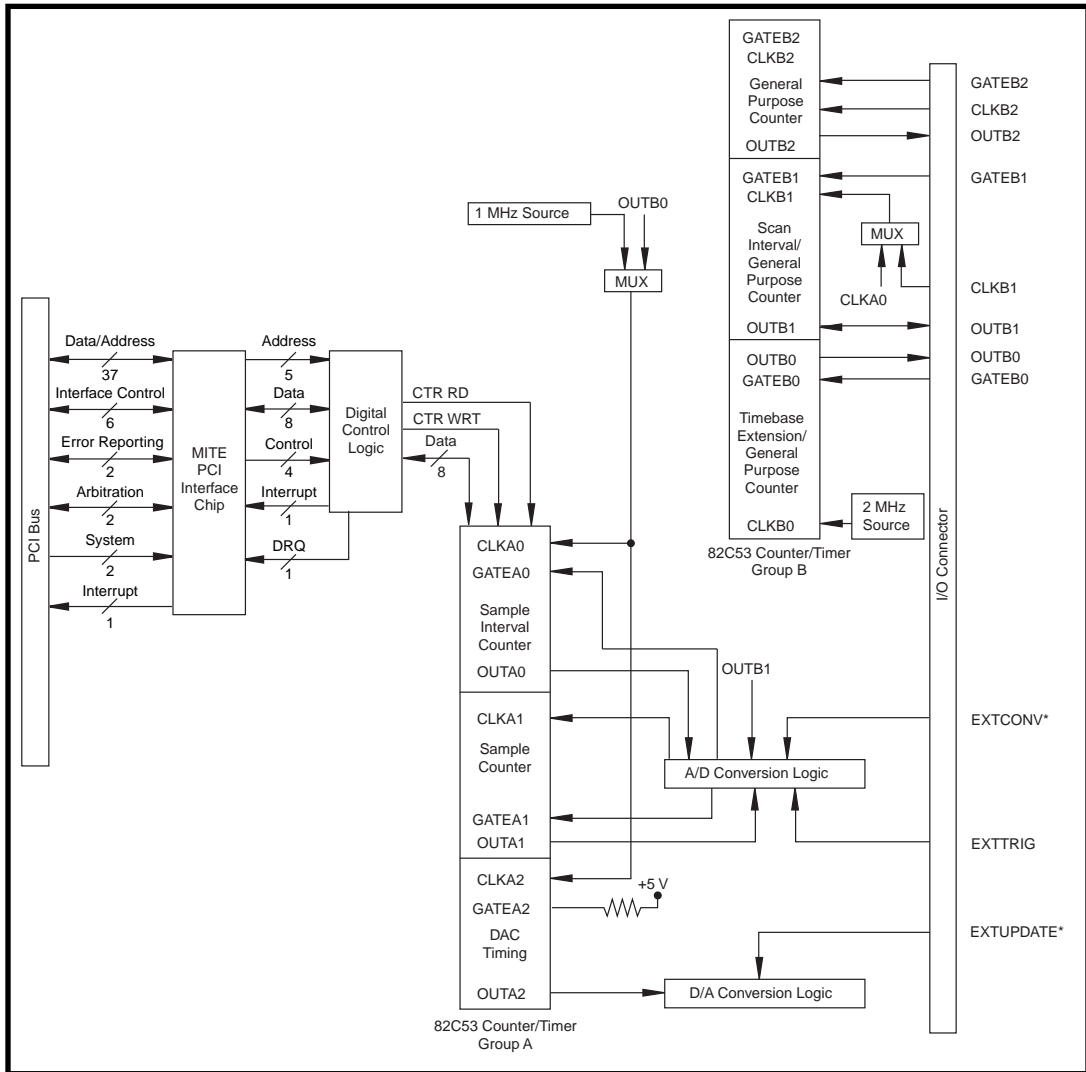

Figure 4-3. Timing Circuitry

Each 82C53 contains three independent 16-bit counter/timers and one 8-bit mode register. Each counter has a CLK input pin, a GATE input pin, and an OUT output pin. You can program all six counter/timers to operate in several useful timing modes.

The first group of counter/timers is called group A and includes A0, A1, and A2. You can use these three counters for internal DAQ and DAC

timing, or you can use the three external timing signals, EXTCONV*, EXTTRIG, and EXTUPDATE*, for DAQ and DAC timing.

The second group of counter/timers is called group B and includes B0, B1, and B2. You can use counters B0 and B1 for internal DAQ and DAC timing, or you can use the external timing signal CLKB1 for analog input timing. If you are not using counters B0 and B1 for internal timing, you can use these counters as general purpose counter/timers. Counter B2 is reserved for external use as a general purpose counter/timer.

For a more detailed description of counter group A and counters B0 and B1, refer to the *Analog Input* and *Analog Output* sections.

Analog Input

The PCI-1200 has eight channels of analog input with software-programmable gain and 12-bit A/D conversion. The PCI-1200 also contains DAQ timing circuitry for automatic timing of multiple A/D conversions and includes advanced options such as external triggering, gating, and clocking. Figure 4-4 shows a block diagram of the analog input circuitry.

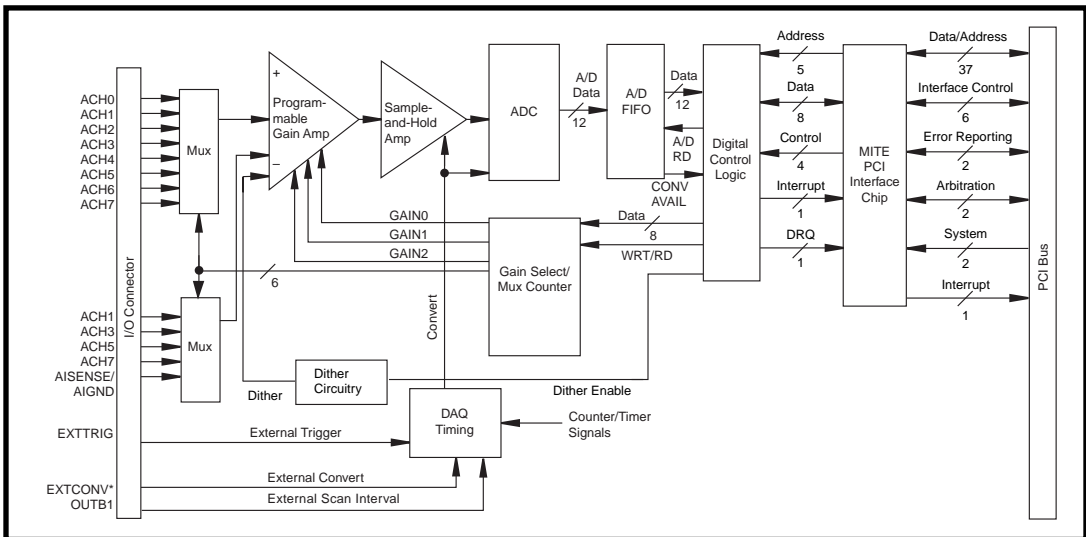

Figure 4-4. Analog Input Circuitry

Analog Input Circuitry

The analog input circuitry consists of two analog input multiplexers, multiplexer (mux) counter/gain select circuitry, a software-programmable gain amplifier, a 12-bit ADC, and a 16-bit sign-extended FIFO memory.

One of the input multiplexers has eight analog input channels (channels 0 through 7). The other multiplexer is connected to channels 1, 3, 5, and 7 for differential mode. The input multiplexers provide input overvoltage protection of ± 35 V powered on and ± 25 V powered off.

The mux counters control the input multiplexers. The PCI-1200 can perform either single-channel data acquisition or multichannel scanned data acquisition. These two modes are software selectable. For single-channel data acquisition, you select the channel and gain before initiating data acquisition. These gain and multiplexer settings remain constant during the entire DAQ process. For multichannel scanned data acquisition, you select the highest numbered channel and gain before initiating data acquisition. Then the mux counter decrements from the highest numbered channel to channel 0 and repeats the process. Thus, you can scan any number of channels from two to eight. Notice that you use the same gain setting for all channels in the scan sequence.

The programmable-gain amplifier applies gain to the input signal, allowing an input analog signal to be amplified before being sampled and converted, thus increasing measurement resolution and accuracy. The instrumentation amplifier gain is software selectable. The PCI-1200 board provides gains of 1, 2, 5, 10, 20, 50, and 100.

The dither circuitry, when enabled, adds approximately 0.5 LSB_{rms} of white Gaussian noise to the signal to be converted to the ADC. This addition is useful for applications involving averaging to increase the resolution of the PCI-1200 to more than 12 bits, as in calibration. In such applications, which are often lower frequency in nature, noise modulation is decreased and differential linearity is improved by the addition of the dither. For high-speed 12-bit applications not involving averaging, you should disable dither because it only adds noise.

When taking DC measurements, such as when calibrating the board, enable dither and average about 1,000 points to take a single reading. This process removes the effects of 12-bit quantization and reduces measurement noise, resulting in improved resolution. Dither, or additive white noise, has the effect of forcing quantization noise to

become a zero-mean random variable rather than a deterministic function of input. For more information on the effects of dither, see “Dither in Digital Audio” by John Vanderkooy and Stanley P. Lipshitz, *Journal of the Audio Engineering Society*, Vol. 35, No. 12, Dec. 1987.

The PCI-1200 uses a 12-bit successive-approximation ADC. The converter’s 12-bit resolution allows it to resolve its input range into 4,095 different steps. The ADC has an input range of ± 5 V and 0 to 10 V.

When an A/D conversion is complete, the ADC clocks the result into the A/D FIFO. The A/D-FIFO is 16 bits wide and 4,096 words deep. This FIFO serves as a buffer to the ADC. The A/D FIFO can collect up to 4,096 A/D conversion values before any information is lost, thus allowing software some extra time to catch up with the hardware. If you store more than 4,096 values in the A/D FIFO before reading from it, an error condition called *A/D FIFO overflow* occurs and you lose A/D conversion information.

The ADC output can be interpreted as either straight binary or two’s complement, depending on which coding scheme you select. Straight binary is the recommended coding scheme for unipolar input mode. With this scheme, the ADC data is interpreted as a 12-bit straight binary number with a range of 0 to +4,095. Two’s complement is the recommended coding scheme for bipolar input mode. With this scheme, the ADC data is interpreted as a 12-bit two’s complement number with a range of -2,048 to +2,047. The ADC output is then sign-extended to 16 bits, causing either a leading 0 or a leading F (hex) to be added, depending on the coding and the sign. Thus, data values read from the FIFO are 16-bits wide.

DAQ Operations

This manual uses the phrase *data acquisition operation* (abbreviated as *DAQ operation*) to refer to a sequence of timed A/D conversions. The PCI-1200 performs DAQ operations in one of three modes: controlled acquisition mode, freerun acquisition mode, and interval scanning acquisition mode. The PCI-1200 performs both single-channel and multichannel scanned data acquisition.

The DAQ timing circuitry consists of various clocks and timing signals that control the DAQ operation. DAQ timing consists of signals that initiate a DAQ operation, time the individual A/D conversions, gate the DAQ operation, and generate scanning clocks. The DAQ operation can

be timed either by the timing circuitry or by externally generated signals. These two timing modes are software configurable.

DAQ operations are initiated either externally through EXTTRIG or through software control. The DAQ operation is terminated either internally by counter A1 of the 82C53 (A) counter/timer circuitry, which counts the total number of samples taken during a controlled operation, or through software control in a freerun operation.

Controlled Acquisition Mode

The PCI-1200 uses two counters, counter A0 and counter A1, to execute DAQ operations in controlled acquisition mode. Counter A0 counts sample intervals, while counter A1 counts samples. In a controlled acquisition mode DAQ operation, the board performs a specified number of conversions, and then the hardware shuts off the conversions. Counter A0 generates the conversion pulses, and counter A1 gates off counter A0 after the programmed count has expired. The number of conversions in a single controlled acquisition mode DAQ operation is limited to a 16-bit count (65,535 conversions).

Freerun Acquisition Mode

The PCI-1200 uses one counter, counter A0, to execute DAQ operations in freerun acquisition mode. Counter A0 continuously generates the conversion pulses as long as GATEA0 is held at a high logic level. The software keeps track of the number of conversions that have occurred and turns off counter A0 either after the required number of conversions has been obtained or after some other user-defined criteria have been met. The number of conversions in a single freerun acquisition mode DAQ operation is unlimited.

Interval Scanning Acquisition Mode

The PCI-1200 uses two counters for interval scanning data acquisition. Counter B1 is used to time the scan interval. Counter A0 times the sample interval. In interval scanning analog input operations, scan sequences are executed at regular, specified intervals. The amount of time that elapses between consecutive scans within the sequence is the *sample interval*. The amount of time that elapses between consecutive scan sequences is the *scan interval*. LabVIEW, LabWindows/CVI, other application software, and NI-DAQ support only multichannel interval scanning. Single-channel interval scanning is available only through register-level programming. Refer to the *PCI-1200*

Register-Level Programming Manual for more information on single-channel interval scanning.

Because interval scanning allows you to specify how frequently scan sequences are executed, it is useful for applications in which you need to sample data at regular but relatively infrequent intervals. For example, to sample channel 1, wait 12 μ s, then sample channel 0; and if you want to repeat this process every 65 ms, then you should define the operation as follows:

- Start channel: ch1 (which gives a scan sequence of “ch1, ch0”)
- Sample interval: 12 μ s
- Scan interval: 65 ms

The first channel will not be sampled until one sample interval from the scan interval pulse. Since the A/D conversion time is 10 μ s, your sample interval must be at least this value to ensure proper operation.

Single-Channel Data Acquisition

The PCI-1200 executes a single-channel analog input operation by performing an A/D conversion on a specified analog input channel every sample interval. The sample interval is the amount of time that elapses between successive A/D conversions. The sample interval is controlled either externally by EXTCONV* or internally by counter A0 of the timing circuitry.

To specify a single-channel analog input operation, select an analog input channel and a gain setting for that channel.

Multichannel Scanned Data Acquisition

The PCI-1200 executes a multichannel DAQ operation by repeatedly scanning a sequence of analog input channels (the same gain is applied to each channel in the sequence). The channels are scanned in decreasing consecutive order; the highest-numbered channel is the start channel, and channel 0 is the last channel in the sequence.

During each scan sequence, the PCI-1200 scans the start channel (the highest-numbered channel) first, then the next highest-numbered channel, and so on until it scans channel 0. The PCI-1200 repeats these scan sequences until the DAQ operation is terminated.

For example, if channel 3 is specified as the start channel, then the scan sequence is as follows:

ch3, ch2, ch1, ch0, ch3, ch2, ch1, ch0, ch3, ch2, ...

To specify the scan sequence for a multichannel scanned analog input operation, select the start channel for the scan sequence.

DAQ Rates

Maximum DAQ rates (number of samples per second) are determined by the conversion period of the ADC plus the sample-and-hold acquisition time. During multichannel scanning, the DAQ rates are further limited by the settling time of the input multiplexers and programmable gain amplifier. After the input multiplexers are switched, the amplifier must be allowed to settle to the new input signal value to within 12-bit accuracy before you perform an A/D conversion, or 12-bit accuracy will not be achieved. The settling time is a function of the gain selected.

Table 4-1 shows the recommended settling time for each gain setting during multichannel scanning. Table 4-2 shows the maximum recommended DAQ rates for both single-channel and multichannel data acquisition. For single-channel scanning, this rate is limited only by the ADC conversion period plus the sample-and-hold acquisition time, specified at 10 μ s. For multichannel data acquisition, observing the DAQ rates in Table 4-2 ensures 12-bit resolution. The hardware is capable of multiple scanning at higher rates than those listed in Table 4-2, but 12-bit resolution is not guaranteed.

Table 4-1. Analog Input Settling Time Versus Gain

Gain	Settling Time (Accuracy $\pm 0.024\%$ [± 1 LSB])
1	10 μ s typ, 14 μ s max
2–10	13 μ s typ, 16 μ s max
20	15 μ s typ, 19 μ s max
50	27 μ s typ, 34 μ s max
100	60 μ s typ, 80 μ s max

Table 4-2. PCI-1200 Maximum Recommended DAQ Rates

Acquisition Mode	Gain	Rate
Single-channel	1, 2, 5, 10, 20, 50, 100	100 kS/s
Multichannel	1	100 kS/s
	2, 5, 10	77 kS/s
	20	66.6 kS/s
	50	37 kS/s
	100	16.6 kS/s

The recommended DAQ rates in Table 4-2 assume that voltage levels on all the channels included in the scan sequence are within range for the given gain and are driven by low-impedance sources.

Analog Output

The PCI-1200 has two channels of 12-bit D/A output. Each analog output channel can provide unipolar or bipolar output. The PCI-1200 also contains timing circuitry for waveform generation timed either externally or internally. Figure 4-5 shows the analog output circuitry.

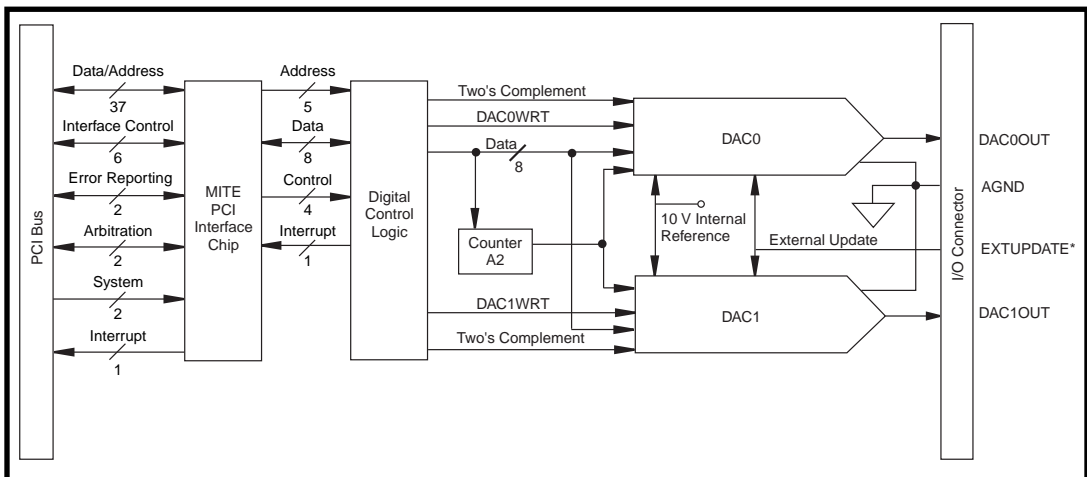

Figure 4-5. Analog Output Circuitry

Analog Output Circuitry

Each analog output channel contains a 12-bit DAC. The DAC in each analog output channel generates a voltage proportional to the 10 V internal reference multiplied by the 12-bit digital code loaded into the DAC. The voltage output from the two DACs is available at the DAC0OUT and DAC1OUT pins.

You can program each DAC channel for a unipolar voltage output or a bipolar voltage output range. A unipolar output gives an output voltage range of 0.0000 to +9.9976 V. A bipolar output gives an output voltage range of -5.0000 to +4.9976 V. For unipolar output, 0.0000 V output corresponds to a digital code word of 0. For bipolar output, -5.0000 V output corresponds to a digital code word of F800 hex. One LSB is the voltage increment corresponding to an LSB change in the digital code word. For both outputs:

$$1\text{LSB} = \frac{10\text{V}}{4,095}$$

DAC Timing

There are two modes in which you can update the DAC voltages. In *immediate update mode*, the DAC output voltage is updated as soon as you write to the corresponding DAC. In *delayed update mode*, the DAC output voltage does not change until a low level is detected either from counter A2 of the timing circuitry or EXTUPDATE*. This mode is useful for waveform generation. These two modes are software selectable.

Digital I/O

The digital I/O circuitry has an 82C55A integrated circuit. The 82C55A is a general purpose programmable peripheral interface containing 24 programmable I/O pins. These pins represent the three 8-bit I/O ports (A, B, and C) of the 82C55A, as well as PA<0..7>, PB<0..7>, and PC<0..7> on the PCI-1200 I/O connector. Figure 4-6 shows the digital I/O circuitry.

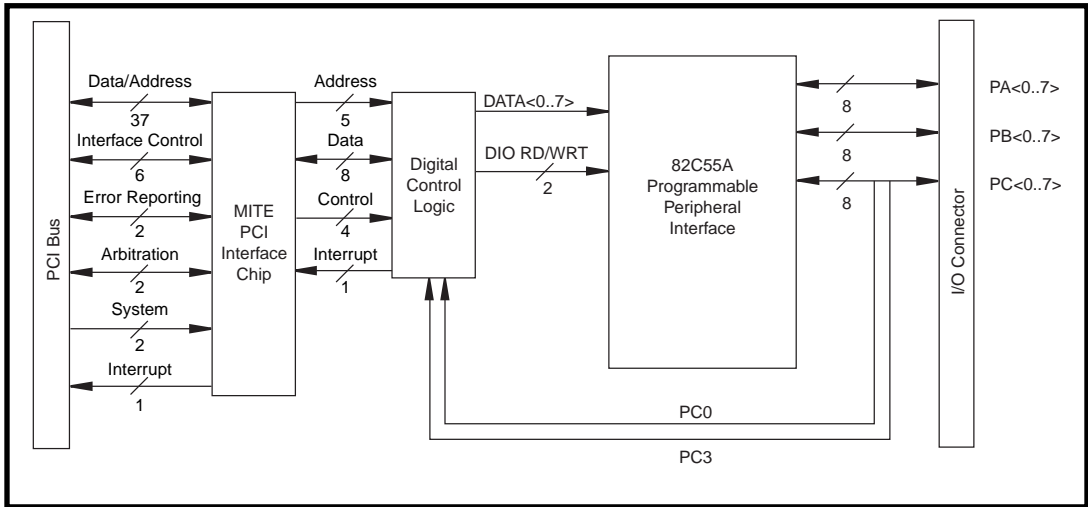

Figure 4-6. Digital I/O Circuitry

All three ports on the 82C55A are TTL-compatible. When enabled, the digital output ports are capable of sinking 2.5 mA of current and sourcing 2.5 mA of current on each digital I/O line. When the ports are not enabled, the digital I/O lines act as high-impedance inputs.

Calibration

Chapter

5

This chapter discusses the calibration procedures for the PCI-1200 analog I/O circuitry. However, the PCI-1200 is factory calibrated, and National Instruments can recalibrate your unit if needed. To maintain the 12-bit accuracy of the PCI-1200 analog input and analog output circuitry, recalibrate at 6-month intervals.

There are four ways to perform calibrations.

- If you have LabVIEW, use the 1200 Calibrate VI. This VI is located in the **Calibration and Configuration** palette.
- If you have LabWindows/CVI, use the `Calibrate_1200` function.
- If you do not have LabVIEW or LabWindows/CVI, use the NI-DAQ `Calibrate_1200` function.
- Use your own register-level writes to the calibration DACs and the EEPROM. (Use this method only if NI-DAQ does not support your operating system.)

To calibrate using register-level writes, you need to use the *PCI-1200 Register-Level Programmer Manual*.

The PCI-1200 is software calibrated. The calibration process involves reading offset and gain errors from the analog input and analog output data areas and writing values to the appropriate calibration DACs to null the errors. There are four calibration DACs associated with the analog input circuitry and four calibration DACs associated with the analog output circuitry, two for each output channel. After the calibration process is complete, each calibration DAC is at a known value. Because these values are lost when the board is powered down, they are also stored in the onboard EEPROM for future reference.

The factory information occupies one half of the EEPROM and is write-protected. The lower half of the EEPROM contains user areas for calibration data. There are four different user areas.

When the PCI-1200 is powered on, or the conditions under which it is operating change, you must load the calibration DACs with the appropriate calibration constants.

If you use the PCI-1200 with NI-DAQ, LabVIEW, LabWindows/CVI, or other application software, the factory calibration constants are automatically loaded into the calibration DAC the first time a function pertaining to the PCI-1200 is called, and again each time you change your configuration (which includes gain). You can, instead, choose to load the calibration DACs with calibration constants from the user areas in the EEPROM or you can recalibrate the PCI-1200 and load these constants directly into the calibration DACs. Calibration software is included with the PCI-1200 as part of your NI-DAQ software.

Calibration at Higher Gains

The PCI-1200 has a maximum gain error of 0.8%. This means that if the board is calibrated at a gain of 1 and if the gain is switched to 100, a maximum error of 32 LSB may result in the reading. Therefore, when you are recalibrating the PCI-1200, you should perform gain calibration at all other gains (2, 5, 10, 20, 50, and 100), and store the corresponding values in the user-gain calibration data area of the EEPROM, thus ensuring a maximum error of 0.02% at all gains. The PCI-1200 is factory-calibrated at all gains, and NI-DAQ automatically loads the correct values into the calibration DACs whenever you switch gains.

Calibration Equipment Requirements

The equipment you use to calibrate the PCI-1200 should have a $\pm 0.001\%$ rated accuracy, which is 10 times as accurate as the PCI-1200. However, calibration equipment with only four times the accuracy as the PCI-1200 and a $\pm 0.003\%$ rated accuracy is acceptable. The inaccuracy of the calibration equipment results only in gain error; offset error is unaffected.

Calibrate the PCI-1200 to a measurement accuracy of ± 0.5 LSBs, which is within $\pm 0.012\%$ of its input range.

For analog input calibration, use a precision DC voltage source, such as a calibrator, with the following specifications.

- Voltage 0 to 10 V
- Accuracy $\pm 0.001\%$ standard
 $\pm 0.003\%$ acceptable

Using the Calibration Function

The `Calibrate_1200` function and the 1200 Calibrate VI can either load the calibration DACs with the factory constants or the user-defined constants stored in the EEPROM, or you can perform your own calibration and directly load these constants into the calibration DACs. To use the `Calibrate_1200` function or the 1200 Calibrate VI for analog input calibration, ground an analog input channel at the I/O connector for offset calibration and apply an accurate voltage reference to another input channel for gain calibration. You should first configure the ADC for RSE mode, then for the correct polarity at which you want to perform data acquisition.

To use the `Calibrate_1200` function or the 1200 Calibrate VI for analog output calibration, the DAC0 and DAC1 outputs must be wrapped back and applied to two other analog input channels. You should first configure the analog input circuitry for RSE and for bipolar polarity, then configure the analog output circuitry for the polarity at which you want to perform output waveform generation.

Refer to your software documentation for more details on the `Calibrate_1200` function and the 1200 Calibrate VI.

Specifications

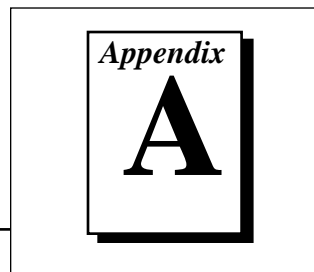

This appendix lists the PCI-1200 specifications. These specifications are typical at 25° C unless otherwise stated.

Analog Input

Input Characteristics

Number of channels Eight single-ended, eight pseudodifferential or four differential, software selectable

Type of ADC..... Successive approximation

Resolution 12 bits, 1 in 4,096

Max sampling rate..... 100 kS/s

Input signal ranges

Board Gain (Software Selectable)	Board Ranges (Software Selectable)	
	±5 V	0 to 10 V
1	±5 V	0 to 10 V
2	±2.5 V	0 to 5 V
5	±1 V	0 to 2 V
10	±500 mV	0 to 1 V
20	±250 mV	0 to 500 mV
50	±100 mV	0 to 200 mV
100	±50 mV	0 to 100 mV

Input coupling DC

Max working voltage (signal + common mode)	In DIFF or NRSE mode, the negative input/AISENSE should remain within ± 5 V of AGND (bipolar), or -5 to 2 V (unipolar). The positive input should remain within the -5 to +10 V range.
Overvoltage protection	± 35 V powered on, ± 25 V powered off
Inputs protected	ACH<0..7>
FIFO buffer size.....	4,096 samples
Data transfers	DMA, interrupts, programmed I/O
DMA mode	Scatter gather
Dither	Available

Transfer Characteristics

Relative accuracy	± 0.5 LSB typ dithered, ± 1.5 LSB max undithered
DNL	± 1 LSB max
No missing codes	12 bits, guaranteed
Offset error	
Pregain error after calibration.....	10 μ V max
Pregain error before calibration	± 20 mV max
Postgain error after calibration	1 mV max
Postgain error before calibration	± 200 mV max
Gain error (relative to calibration reference)	
After calibration.....	0.02% of reading max
Before calibration	$\pm 2\%$ of reading max
Gain $\neq 1$ with gain error adjusted to 0 at gain = 1	$\pm 0.8\%$ of reading max

Amplifier Characteristics

Input impedance

Normal powered on.....	100 G Ω in parallel with 50 pF
Powered off.....	4.7 k Ω min
Overload.....	4.7 k Ω min

Input bias current ± 100 pA

Input offset current..... ± 100 pA

CMRR 70 dB, DC to 60 Hz

Dynamic Characteristics

Bandwidth

Small signal (-3 dB)

Gain	Bandwidth
1-10	250 kHz
20	150 kHz
50	60 kHz
100	30 kHz

Settling time for full-scale step

Gain	Settling Time (Accuracy $\pm 0.024\%$ (± 1 LSB))
1	10 μ s typ, 14 μ s max
2-10	13 μ s typ, 16 μ s max
20	15 μ s typ, 19 μ s max
50	27 μ s typ, 34 μ s max
100	60 μ s typ, 80 μ s max

System noise (including quantization error)

Gain	Dither off	Dither on
1-50	0.3 LSB rms	0.5 LSB rms
100	0.5 LSB rms	0.7 LSB rms

Stability

Recommended warm-up time.....	15 min.
Offset temperature coefficient	
Pregain.....	$\pm 15 \mu\text{V}/^\circ\text{C}$
Postgain	$\pm 100 \mu\text{V}/^\circ\text{C}$
Gain temperature coefficient	$\pm 40 \text{ ppm}/^\circ\text{C}$

Explanation of Analog Input Specifications

Relative accuracy is a measure of the linearity of an ADC. However, relative accuracy is a tighter specification than a *nonlinearity* specification. Relative accuracy indicates the maximum deviation from a straight line for the analog-input-to-digital-output transfer curve. If an ADC has been calibrated perfectly, this straight line is the ideal transfer function, and the relative accuracy specification indicates the worst deviation from the ideal that the ADC permits.

A relative accuracy specification of ± 1 LSB is roughly equivalent to, but not the same as, a ± 0.5 LSB nonlinearity or integral nonlinearity specification because relative accuracy encompasses both nonlinearity and variable quantization uncertainty, a quantity often mistakenly assumed to be exactly ± 0.5 LSB. Although quantization uncertainty is ideally ± 0.5 LSB, it can be different for each possible digital code and is actually the analog width of each code. Thus, it is more specific to use relative accuracy as a measure of linearity than it is to use what is normally called nonlinearity, because relative accuracy ensures that the *sum* of quantization uncertainty and A/D conversion error does not exceed a given amount.

Integral nonlinearity (INL) in an ADC is an often ill-defined specification that is supposed to indicate a converter's overall A/D transfer linearity. The manufacturer of the ADC chip National Instruments uses on the PCI-1200 specifies its integral nonlinearity by stating that the analog center of any code will not deviate from a straight line by more than ± 1 LSB. This specification is misleading because, although a particularly wide code's center may be found within ± 1 LSB of the ideal, one of its edges may be well beyond ± 1.5 LSB; thus, the ADC would have a relative accuracy of that amount. National Instruments tests its boards to ensure that they meet all three linearity specifications defined in this appendix.

Differential nonlinearity (DNL) is a measure of deviation of code widths from their theoretical value of 1 LSB. The width of a given code is the size of the range of analog values that can be input to produce that code, ideally 1 LSB. A specification of ± 1 LSB differential nonlinearity ensures that no code has a width of 0 LSBs (that is, no missing codes) and that no code width exceeds 2 LSBs.

System noise is the amount of noise seen by the ADC when there is no signal present at the input of the board. The amount of noise that is reported directly (without any analysis) by the ADC is not necessarily the amount of real noise present in the system, unless the noise is considerably greater than 0.5 LSB rms. Noise that is less than this magnitude produces varying amounts of flicker, and the amount of flicker seen is a function of how near the real mean of the noise is to a code transition. If the mean is near or at a transition between codes, the ADC flickers evenly between the two codes, and the noise is very near 0.5 LSB. If the mean is near the center of a code and the noise is relatively small, very little or no flicker is seen, and the noise is reported by the ADC as nearly 0 LSB. From the relationship between the mean of the noise and the measured rms magnitude of the noise, the character of the noise can be determined. National Instruments has determined that the character of the noise in the PCI-1200 is fairly Gaussian, so the noise specifications given are the amounts of pure Gaussian noise required to produce our readings.

Explanation of Dither

The *dither circuitry*, when enabled, adds approximately 0.5 LSB rms of white Gaussian noise to the signal to be converted to the ADC. This addition is useful for applications involving averaging to increase the resolution of the PCI-1200 to more than 12 bits, as in calibration. In such applications, which are often lower frequency in nature, noise modulation is decreased and differential linearity is improved by the addition of dither. For high-speed 12-bit applications not involving averaging, dither should be disabled because it only adds noise.

When taking DC measurements, such as when calibrating the board, enable dither and average about 1,000 points to take a single reading. This process removes the effects of 12-bit quantization and reduces measurement noise, resulting in improved resolution. Dither, or additive white noise, has the effect of forcing quantization noise to become a zero-mean random variable rather than a deterministic function of input. For more information on the effects of dither, see

"Dither in Digital Audio" by John Vanderkooy and Stanley P. Lipshitz, *Journal of the Audio Engineering Society*, Vol. 35, No. 12, Dec. 1987.

Explanation of DAQ Rates

Maximum DAQ rates (number of S/s) are determined by the conversion period of the ADC plus the sample-and-hold acquisition time, which is specified at 10 μ s. During multichannel scanning, the DAQ rates are further limited by the settling time of the input multiplexers and programmable gain amplifier. After the input multiplexers are switched, the amplifier must be allowed to settle to the new input signal value to within 12-bit accuracy. The settling time is a function of the gain selected.

Analog Output

Output Characteristics

Number of channels	Two voltage
Resolution	12 bits, 1 in 4,096
Typical update rate	20 S/s–1 kS/s, system dependent
Type of DAC	Double buffered
Data transfers	Interrupts, programmed I/O

Transfer Characteristics

Relative accuracy (INL)	± 0.25 LSB typ, ± 0.50 LSB max
DNL	± 0.25 LSB typ, ± 0.75 LSB max
Monotonicity	12 bits, guaranteed
Offset error	
After calibration	± 0.2 mV max
Before calibration	± 50 mV max
Gain error (relative to internal reference)	
After calibration	0.004% of reading max
Before calibration	$\pm 1\%$ of reading max

Voltage Output

Ranges	0 to 10 V, ± 5 V, software selectable
Output coupling	DC
Output impedance	0.2 Ω typ
Current drive	± 2 mA
Protection	Short circuit to ground
Power-on state	0 V

Dynamic Characteristics

Settling time to full-scale range (FSR) .. 5 μ s

Stability

Offset temperature coefficient..... ± 50 μ V/ $^{\circ}$ C

Gain temperature coefficient..... ± 30 ppm/ $^{\circ}$ C

Explanation of Analog Output Specifications

Relative accuracy in a D/A system is the same as nonlinearity because no uncertainty is added due to code width. Unlike an ADC, every digital code in a D/A system represents a specific analog value rather than a range of values. The relative accuracy of the system is therefore limited to the worst-case deviation from the ideal correspondence (a straight line), except noise. If a D/A system has been calibrated perfectly, the relative accuracy specification reflects its worst-case absolute error.

DNL in a D/A system is a measure of deviation of code width from 1 LSB. In this case, code width is the difference between the analog values produced by consecutive digital codes. A specification of ± 1 LSB differential nonlinearity ensures that the code width is always greater than 0 LSBs (guaranteeing monotonicity) and is always less than 2 LSBs.

Digital I/O

Number of channels24 I/O (three 8-bit ports; uses 82C55A PPI)

CompatibilityTTL

Digital logic levels

Level	Min	Max
Input low voltage	-0.3 V	0.8 V
Input high voltage	2.2 V	5.3 V
Output low voltage ($I_{OUT} = 2.5 \text{ mA}$)	—	0.4 V
Output high voltage ($I_{OUT} = -40 \mu\text{A}$)	4.2 V	—
($I_{OUT} = -2.5 \text{ mA}$)	3.7 V	—

Power-on stateAll ports mode 0 input

Protection-0.5 to 5.5 V powered on,
±0.5 V powered off

Data transfersInterrupts, programmed I/O

Timing I/O

Number of channels3 counter/timers

Protection-0.5 to 5.5 V powered on,
±0.5 V powered off

Resolution

Counter/timers16 bits

CompatibilityTTL

Base clock available2 MHz

Base clock accuracy.....±50 ppm max

Max source frequency.....8 MHz

Min source pulse duration125 ns

Min gate pulse duration50 ns

Digital logic levels

Level	Min	Max
Input low voltage	-0.3 V	0.8 V
Input high voltage	2.2 V	5.3 V
Output low voltage ($I_{OUT} = 2.1$ mA)	—	0.45 V
Output high voltage ($I_{OUT} = -0.92$ mA)	3.7 V	—

Protection -0.5 to 5.5 V powered on,
 ± 0.5 V powered off

Data transfer Interrupts, programmed I/O

Digital Trigger

Compatibility TTL

Response Rising edge

Pulse width 50 ns min

Bus Interface

Type Slave

Power Requirement

Power consumption 425 mA at ± 5 VDC ($\pm 5\%$)

Power available at I/O connector +4.65 to +5.25 V fused at 1 A

Physical

Dimensions 17.45 by 10.56 cm
 (6.87 by 4.16 in.)

I/O connector 50-pin male

Environment

Operating temperature	0° to 50° C
Storage temperature	-55° to 150° C
Relative humidity.....	5% to 90% noncondensing

Customer Communication

Appendix

B

For your convenience, this appendix contains forms to help you gather the information necessary to help us solve your technical problems and a form you can use to comment on the product documentation. When you contact us, we need the information on the Technical Support Form and the configuration form, if your manual contains one, about your system configuration to answer your questions as quickly as possible.

National Instruments has technical assistance through electronic, fax, and telephone systems to quickly provide the information you need. Our electronic services include a bulletin board service, an FTP site, a Fax-on-Demand system, and e-mail support. If you have a hardware or software problem, first try the electronic support systems. If the information available on these systems does not answer your questions, we offer fax and telephone support through our technical support centers, which are staffed by applications engineers.

Electronic Services



Bulletin Board Support

National Instruments has BBS and FTP sites dedicated for 24-hour support with a collection of files and documents to answer most common customer questions. From these sites, you can also download the latest instrument drivers, updates, and example programs. For recorded instructions on how to use the bulletin board and FTP services and for BBS automated information, call (512) 795-6990. You can access these services at:

United States: (512) 794-5422

Up to 14,400 baud, 8 data bits, 1 stop bit, no parity

United Kingdom: 01635 551422

Up to 9,600 baud, 8 data bits, 1 stop bit, no parity

France: 01 48 65 15 59

Up to 9,600 baud, 8 data bits, 1 stop bit, no parity



FTP Support

To access our FTP site, log on to our Internet host, `ftp.natinst.com`, as anonymous and use your Internet address, such as `joesmith@anywhere.com`, as your password. The support files and documents are located in the `/support` directories.



Fax-on-Demand Support

Fax-on-Demand is a 24-hour information retrieval system containing a library of documents on a wide range of technical information. You can access Fax-on-Demand from a touch-tone telephone at (512) 418-1111.



E-Mail Support (currently U.S. only)

You can submit technical support questions to the applications engineering team through e-mail at the Internet address listed below. Remember to include your name, address, and phone number so we can contact you with solutions and suggestions.

support@natinst.com

Fax and Telephone Support

National Instruments has branch offices all over the world. Use the list below to find the technical support number for your country. If there is no National Instruments office in your country, contact the source from which you purchased your software to obtain support.



Telephone



Fax

Australia	03 9879 5166	03 9879 6277
Austria	0662 45 79 90 0	0662 45 79 90 19
Belgium	02 757 00 20	02 757 03 11
Canada (Ontario)	905 785 0085	905 785 0086
Canada (Quebec)	514 694 8521	514 694 4399
Denmark	45 76 26 00	45 76 26 02
Finland	09 527 2321	09 502 2930
France	01 48 14 24 24	01 48 14 24 14
Germany	089 741 31 30	089 714 60 35
Hong Kong	2645 3186	2686 8505
Israel	03 5734815	03 5734816
Italy	02 413091	02 41309215
Japan	03 5472 2970	03 5472 2977
Korea	02 596 7456	02 596 7455
Mexico	5 520 2635	5 520 3282
Netherlands	0348 433466	0348 430673
Norway	32 84 84 00	32 84 86 00
Singapore	2265886	2265887
Spain	91 640 0085	91 640 0533
Sweden	08 730 49 70	08 730 43 70
Switzerland	056 200 51 51	056 200 51 55
Taiwan	02 377 1200	02 737 4644
U.K.	01635 523545	01635 523154

Technical Support Form

Photocopy this form and update it each time you make changes to your software or hardware, and use the completed copy of this form as a reference for your current configuration. Completing this form accurately before contacting National Instruments for technical support helps our applications engineers answer your questions more efficiently.

If you are using any National Instruments hardware or software products related to this problem, include the configuration forms from their user manuals. Include additional pages if necessary.

Name _____

Company _____

Address _____

Fax (____) _____ Phone (____) _____

Computer brand _____ Model _____ Processor _____

Operating system (include version number) _____

Clock speed _____ MHz RAM _____ MB Display adapter _____

Mouse ___yes ___no Other adapters installed _____

Hard disk capacity _____ MB Brand _____

Instruments used _____

National Instruments hardware product model _____ Revision _____

Configuration _____

National Instruments software product _____ Version _____

Configuration _____

The problem is: _____

List any error messages: _____

The following steps reproduce the problem: _____

PCI-1200 Hardware and Software Configuration Form

Record the settings and revisions of your hardware and software on the line to the right of each item. Complete a new copy of this form each time you revise your software or hardware configuration, and use this form as a reference for your current configuration. Completing this form accurately before contacting National Instruments for technical support helps our applications engineers answer your questions more efficiently.

National Instruments Products

Serial number _____

Base memory address of PCI-1200 _____

Interrupt line value _____

NI-DAQ, LabVIEW, LabWindows/CVI, ComponentWorks, or VirtualBench _____

Other Products

Computer make and model _____

Microprocessor _____

Clock frequency or speed _____

Amount of memory _____

Type of video board installed _____

Operating system _____

Operating system version _____

System and finders version _____

Programming language _____

Programming language version _____

Other boards in system _____

Base memory address of other boards _____

Documentation Comment Form

National Instruments encourages you to comment on the documentation supplied with our products. This information helps us provide quality products to meet your needs.

Title: *PCI-1200 User Manual*

Edition Date: January 1997

Part Number: 320942B-01

Please comment on the completeness, clarity, and organization of the manual.

If you find errors in the manual, please record the page numbers and describe the errors.

Thank you for your help.

Name _____

Title _____

Company _____

Address _____

Phone (____) _____ Fax (____) _____

Mail to: Technical Publications
National Instruments Corporation
6504 Bridge Point Parkway
Austin, TX 78730-5039

Fax to: Technical Publications
National Instruments Corporation
(512) 794-5678

Prefix	Meaning	Value
G-	giga-	10^9
k-	kilo-	10^3
m-	milli-	10^{-3}
M-	mega-	10^6
n-	nano-	10^{-9}
p-	pico-	10^{-12}
μ -	micro-	10^{-6}

Numbers/Symbols

°	degrees
>	greater than
≥	greater than or equal to
<	less than
-	negative of, or minus
Ω	ohms
%	percent

Glossary

±	plus or minus
+	positive of, or plus
+5 V	+5 Volts signal

A

A	amperes
AC	alternating current
ACH <0..7>	analog channel 0 through 7 signals
ACK*	acknowledge input signal
A/D	analog-to-digital
ADC	analog-to-digital converter—an electronic device, often an integrated circuit, that converts an analog voltage to a digital number
AGND	analog ground signal
AI	analog input
AISENSE/AIGND	analog input sense/analog input ground signal
ANSI	American National Standards Institute
AO	analog output
AWG	American Wire Gauge

C

C	Celsius
CALDAC	calibration digital-to-analog converter
CLKB1, CLKB2	counter B1, B2 clock signals

cm	centimeters
CMRR	common-mode rejection ratio—a measure of an instrument's ability to reject interference from a common-mode signal, usually expressed in decibels (dB)

D

D/A	digital-to-analog
DAC	digital-to-analog converter—an electronic device, often an integrated circuit, that converts a digital number into a corresponding analog voltage or current
DAC0OUT, DAC1OUT	digital-to-analog converter 0, 1 output signals
DAQ	data acquisition— a system that uses the computer to collect, receive, and generate electrical signals
dB	decibel—the unit for expressing a logarithmic measure of the ratio of two signal levels: $\text{dB}=20\log_{10} V_1/V_2$, for signals in volts
DGND	digital ground signal
DI	digital input
DIFF	differential
DIO	digital input/output
DMA	direct memory access
DNL	differential nonlinearity
DO	digital output

E

EEPROM	electrically erasable programmable read-only memory—ROM that can be erased with an electrical signal and reprogrammed
EXTCONV*	external convert signal

EXTTRIG external trigger signal

EXTUPDATE* external update signal

F

F farad

ft feet

G

GATB <0..2> counter B0, B1, B2 gate signals

H

hex hexadecimal

I

IBF input buffer full signal

in. inches

INL integral nonlinearity—a measure in LSB of the worst-case deviation from the ideal A/D or D/A transfer characteristic of the analog I/O circuitry

I/O input/output

L

LED light-emitting diode

LSB least significant bit

M

m	meters
max	maximum
MB	megabytes of memory
min.	minutes
min	minimum
MIO	multifunction I/O
MSB	most significant bit
mux	multiplexer—a switching device with multiple inputs that connects one of its inputs to its output.

N

NRSE	nonreferenced single-ended mode—all measurements are made with respect to a common (NRSE) measurement system reference, but the voltage at this reference can vary with respect to the measurement system ground
------	--

O

OBF*	output buffer full signal
OUTB0, OUTB1	counter B0, B1 output signals

P

PA, PB, PC <0..7>	port A, B, or C 0 through 7 signals
PCI	Peripheral Component Interconnect—a high-performance expansion bus architecture originally developed by Intel to replace ISA and EISA. It is achieving widespread acceptance as a standard for PCs and work-stations; it offers a theoretical maximum transfer rate of 132 Mbytes/s.

port	a digital port, consisting of four or eight lines of digital input and/or output
POSTTRIG	posttrigger mode
postriggering	the technique used on a DAQ board to acquire a programmed number of samples after trigger conditions are met
PPI	programmable peripheral interface
PRETRIG	pretrigger mode
pretriggering	the technique used on a DAQ board to keep a continuous buffer filled with data, so that when the trigger conditions are met, the sample includes the data leading up to the trigger condition

R

R _{EXT}	external resistance
rms	root mean square
RSE	referenced single-ended mode—all measurements are made with respect to a common reference measurement system or a ground. Also called a grounded measurement system.

S

s	seconds
S	samples
scan	one or more analog or digital input samples. Typically, the number of input samples in a scan is equal to the number of channels in the input group. For example, one pulse from the scan clock produces one scan which acquires one new sample from every analog input channel in the group.
SCXI	Signal Conditioning eXtensions for Instrumentation—the National Instruments product line for conditioning low-level signals within an external chassis near sensors so only high-level signals are sent to DAQ boards in the noisy PC environment

signal conditioning	the manipulation of signals to prepare them for digitizing
STB	strobe input signal
T	
TTL	transistor-transistor logic
typ	typical
V	
V	volts
V_{in}	positive/negative input voltage
V_{cm}	common-mode noise
VDC	volts direct current
V_{diff}	differential input voltage
V_{EXT}	external voltage
VI	virtual instrument—(1) a combination of hardware and/or software elements, typically used with a PC, that has the functionality of a classic stand-alone instrument (2) a LabVIEW software module (VI), which consists of a front panel user interface and a block diagram program
V_m	measured voltage
V_{rms}	volts, root-mean-square
V_s	signal source
W	
W	watts

Numbers

+5 V signal (table), 3-4

A

ACH<7..0> signal

definition (table), 3-3

input ranges (table)

bipolar analog input, 3-5

unipolar analog input, 3-6

ACK* signal, 3-20

A/D FIFO, 4-7

AGND signal (table), 3-3

AISENSE/AIGND signal

analog common signal, 3-5

definition (table), 3-3

analog input

circuitry, 4-6 to 4-7

illustration, 4-5

configuration. *See analog input configuration.*

DAQ operations, 4-7 to 4-10

controlled acquisition mode, 4-8

freerun acquisition mode, 4-8

interval scanning acquisition mode,
4-8 to 4-9

multichannel scanned data
acquisition, 4-9 to 4-10

single-channel data acquisition, 4-9

DAQ rates, 4-10 to 4-11

maximum recommended rates
(table), 4-11

settling time vs. gain (table), 4-10

input modes. *See analog input modes.*

polarity

configuration, 2-3

settings (table), 2-2

signal connections. *See analog input signal connections.*

specifications, A-1 to A-5

theory of operation, 4-5 to 4-11

analog input configuration, 2-2 to 2-5

analog I/O settings (table), 2-2

differential connections

purpose and use, 3-10

recommended input configurations
(table), 3-9

floating signal sources

differential connections, 3-11 to 3-13

recommended input configurations
(table), 3-9

ground-referenced signal sources

differential connections, 3-10 to 3-11

recommended input configurations
(table), 3-9

input modes, 2-3 to 2-5

input polarity, 2-3

analog input modes, 2-3 to 2-5

DIFF. *See also differential connections.*

definition (table), 2-4

purpose and use, 2-5

recommended input configurations
(table), 3-9

NRSE

definition (table), 2-4

purpose and use, 2-4 to 2-5

recommended input configurations
(table), 3-9

- single-ended connections for
 - ground-referenced signal sources, 3-14 to 3-15
 - RSE**
 - definition (table), 2-4
 - purpose and use, 2-4
 - recommended input configurations (table), 3-9
 - single-ended connections for floating signal sources, 3-13 to 3-14
 - analog input signal connections
 - bipolar signal range vs. gain (table), 3-5
 - common-mode signal rejection, 3-15
 - differential connections
 - floating signal sources, 3-11 to 3-13
 - grounded signal sources, 3-10 to 3-11
 - purpose and use, 3-10
 - when to use, 3-10
 - exceeding maximum input voltage ratings (warning), 3-5
 - floating signal sources, 3-7
 - ground-referenced signal sources, 3-7 to 3-8
 - input configurations, 3-8 to 3-15
 - instrumentation amplifier, 3-6
 - pins, 3-5
 - recommended input configurations (table), 3-9
 - single-ended connections, 3-13
 - floating signal sources (RSE configuration), 3-13 to 3-14
 - grounded signal sources (NRSE configuration), 3-14 to 3-15
 - when to use, 3-13
 - types of signal sources, 3-7 to 3-8
 - unipolar signal range vs. gain (table), 3-6
 - analog input specifications, A-1 to A-5
 - amplifier characteristics, A-3
 - dynamic characteristics, A-3 to A-4
 - explanation, A-4 to A-5
 - input characteristics, A-1 to A-2
 - stability, A-4
 - transfer characteristics, A-2
 - analog output
 - circuitry, 4-12
 - illustration, 4-11
 - DAC timing, 4-12
 - polarity
 - configuration, 2-3
 - settings (table), 2-2
 - signal connections, 3-16 to 3-17
 - theory of operation, 4-11 to 4-12
 - analog output specifications, A-6 to A-7
 - dynamic characteristics, A-7
 - explanation, A-7
 - output characteristics, A-6
 - stability, A-7
 - transfer characteristics, A-6
 - voltage output, A-7
- ## B
- bipolar signal range vs. gain (table), 3-5
 - bulletin board support, B-1
 - bus interface specifications, A-9
- ## C
- cabling, custom, 1-5
 - Calibrate_1200 function, 5-3
 - calibration, 5-1 to 5-3
 - EEPROM contents, 5-1 to 5-2
 - equipment requirements, 5-2 to 5-3
 - higher gains, 5-2
 - methods, 5-1
 - overview, 5-1
 - using the Calibrate_1200 function, 5-3
 - CLK signals
 - general-purpose timing signal
 - connections, 3-29 to 3-33
 - timing requirements signals (figure), 3-33
 - CLKB1 signal, 3-4

CLKB2 signal, 3-4
 CNTINT signal, 3-28
 common mode signal rejection considerations, 3-15
 ComponentWorks application software, 1-2
 configuration
 analog input
 analog I/O settings (table), 2-2
 input modes, 2-3 to 2-5
 input polarity, 2-3
 analog output polarity, 2-3
 controlled acquisition mode, 4-8
 Counter 0 on 82C53(A) counter/timer, 3-25
 Counter 1 on 82C53(A) counter/timer, 3-25
 counter/timers, 4-3 to 4-5
 circuitry (figure), 4-4
 custom cabling, 1-5
 customer communication, *xii*, B-1 to B-2

D

DAC timing, 4-12
 DAC00OUT signal (table), 3-3
 DAC10OUT signal (table), 3-3
 DACWRT signal, 3-28
 DAQ and general-purpose timing signal connections, 3-25 to 3-33
 DAQ timing connections, 3-25 to 3-29
 general-purpose timing connections, 3-29 to 3-33
 pins, 3-25
 power connections, 3-33
 DAQ operations, 4-7 to 4-10
 controlled acquisition mode, 4-8
 freerun acquisition mode, 4-8
 interval scanning acquisition mode, 4-8 to 4-9
 multichannel scanned data acquisition, 4-9 to 4-10
 single-channel data acquisition, 4-9
 DAQ rates, 4-10 to 4-11

 explanation, A-6
 maximum recommended rates (table), 4-11
 settling time vs. gain (table), 4-10
 DAQ timing connections, 3-25 to 3-29. *See also general-purpose timing signal connections.*
 EXTCONV* signal, 3-25 to 3-27
 EXTCONV* signal timing (figure), 3-25
 EXTTRIG signal, 3-26 to 3-27
 EXTUPDATE* signal, 3-28 to 3-29
 interval scanning, 3-27 to 3-28
 pins, 3-25
 posttrigger and pretrigger modes, 3-26 to 3-27
 posttrigger timing (figure), 3-26
 pretrigger timing (figure), 3-27
 DATA signal, 3-21
 DGND signal (table), 3-3
 DIFF input
 configuration, 2-5
 definition (table), 2-4
 recommended input configurations (table), 3-9
 differential connections
 DIFF configuration, 3-10
 floating signal sources, 3-11 to 3-13
 ground-referenced signal sources, 3-10 to 3-11
 purpose and use, 3-10
 when to use, 3-10
 differential nonlinearity (DNL)
 analog input, A-5
 analog output, A-7
 digital I/O circuitry
 illustration, 4-13
 theory of operation, 4-12 to 4-13
 digital I/O signal connections
 illustration, 3-19
 logical inputs and outputs, 3-18

- pins, 3-17
- Port C pin connections, 3-19 to 3-20
- timing specifications, 3-20 to 3-24
 - mode 1 input timing, 3-22
 - mode 1 output timing, 3-23
 - mode 2 bidirectional timing, 3-24
- digital I/O specifications, A-8
- digital trigger, A-9
- dither circuitry
 - explanation, A-5 to A-6
 - theory of operation, 4-6 to 4-7
- DNL (differential nonlinearity)
 - analog input, A-5
 - analog output, A-7
- documentation
 - conventions used in manual, *x*
 - National Instruments documentation set, *xi*
 - organization of manual, *ix* to *x*
 - related documentation, *xii*

E

- EEPROM contents, 5-1 to 5-2
- electronic support services, B-1 to B-2
- e-mail support, B-2
- environment specifications, A-10
- equipment, optional, 1-5
- event-counting
 - general-purpose timing signal connections, 3-29
 - with external switch gating (figure), 3-30
- EXTCONV* signal
 - definition (table), 3-4
 - interval-scanning data acquisition, 3-27 to 3-28
 - maximum voltage input rating, 3-29
 - timing connections, 3-25 to 3-27
 - signal timing (figure), 3-25
- EXTTRIG signal
 - DAQ timing, 3-26 to 3-27

- definition (table), 3-4
- maximum voltage input rating, 3-29

EXTUPDATE* signal

- DAQ timing, 3-28 to 3-29
- definition (table), 3-4
- maximum voltage input rating, 3-29
- updating DAC output (figure), 3-29

F

- fax and telephone support, B-2
- Fax-on-Demand support, B-2
- floating signal sources
 - differential connections, 3-11 to 3-13
 - purpose and use, 3-7
 - recommended input configurations (table), 3-9
 - single-ended connections (RSE configuration), 3-13 to 3-14
- freerun acquisition mode, 4-8
- frequency measurement
 - general-purpose timing signal connections, 3-29 to 3-33
 - illustration, 3-31
- FTP support, B-1

G

- GATB0 signal, 3-4
- GATB1 signal, 3-4
- GATB2 signal, 3-4
- GATE signals
 - general-purpose timing signal connections, 3-29 to 3-33
 - interval-scanning data acquisition, 3-27 to 3-28
 - timing requirements signals (figure), 3-33
- general-purpose timing signal connections.
 - See also DAQ timing connections.*
 - event-counting, 3-29
 - with external switch gating (figure), 3-30

- frequency measurement, 3-30 to 3-31
 - illustration, 3-31
- GATE, CLK, and OUT signals, 3-29 to 3-33
 - pins, 3-25
 - pulse-width measurement, 3-30
 - specifications and ratings, 3-32
 - square wave generation, 3-29
 - time-lapse measurement, 3-30
 - timing requirements for GATE, CLK, and OUT signals (figure), 3-33
- ground-referenced signal sources
 - differential connections, 3-10 to 3-11
 - purpose and use, 3-7
 - recommended input configurations (table), 3-9
 - single-ended connections (NRSE configuration), 3-14 to 3-15

I

- IBF signal, 3-20
- INL (integral nonlinearity), A-4
- input configurations. *See analog input configuration.*
- installation
 - PCI-1200, 2-1
 - software installation, 2-1
 - unpacking the PCI-1200, 1-6
- instrumentation amplifier
 - illustration, 3-6
 - purpose and use, 3-6 to 3-7
 - theory of operation, 4-6
- integral nonlinearity (INL), A-4
- interval scanning DAQ operation
 - description, 3-27
 - signal timing (figure), 3-28
 - theory of operation, 4-8 to 4-9
- INTR signal, 3-21
- I/O connector

- exceeding maximum ratings (warning), 3-1
- pin assignments (figure), 3-2

L

- LabVIEW application software, 1-2
- LabWindows/CVI application software, 1-2

M

- manual. *See documentation.*
- mode 1 input timing, 3-22
- mode 1 output timing, 3-23
- mode 2 bidirectional timing, 3-24
- multichannel scanned data acquisition, 4-9 to 4-10
- multiplexers, analog input, 4-6
- mux counters, 4-6

N

- NI-DAQ driver software, 1-3 to 1-4
- noise, system, A-5
- NRSE input
 - configuration, 2-4 to 2-5
 - definition (table), 2-4
 - recommended input configurations (table), 3-9
 - single-ended connections for ground-referenced signal sources, 3-14 to 3-15

O

- OBFB* signal, 3-21
- operation of PCI-1200. *See theory of operation.*
- OUT signals
 - general-purpose timing signal connections, 3-29 to 3-33
 - timing requirements signals (figure), 3-33
- OUTB0 signal, 3-4

OUTB1 signal
 definition (table), 3-4
 interval-scanning signal timing, 3-28
 maximum voltage input rating, 3-29

OUTB2 signal, 3-4

P

PA<7..0> signal (table), 3-3
 PB<7..0> signal (table), 3-3
 PC<7..0> signal (table), 3-3

PCI interface circuitry
 block diagram, 4-3
 theory of operation, 4-2 to 4-3

PCI-1200
 block diagram, 4-1
 configuration. *See configuration.*
 custom cabling, 1-5
 features, 1-1
 installation, 2-1
 optional equipment, 1-5
 requirements for getting started, 1-1 to 1-2
 software programming choices
 National Instruments application
 software, 1-2 to 1-3
 NI-DAQ driver software, 1-3 to 1-4
 register-level programming, 1-4
 theory of operation. *See theory of operation.*
 unpacking, 1-6

physical specifications, A-9
 pin assignments for I/O connector (figure), 3-2

polarity
 analog input, 2-3
 analog output, 2-3
 settings (table), 2-2

Port C signal assignments (table), 3-20

POSTTRIG mode, 3-26

posttrigger DAQ timing (figure), 3-26

power connections, 3-33

power requirement specifications, A-9

PRETRIG mode, 3-26 to 3-27
 pretrigger DAQ timing (figure), 3-27
 programmable-gain amplifier, 4-6
 pulse generation, 3-29
 pulse-width measurement, 3-30

R

RD* signal, 3-21

referenced single-ended mode. *See RSE input.*

register-level programming, 1-4

relative accuracy
 analog input, A-4
 analog output, A-7

RSE input
 configuration, 2-4
 definition (table), 2-4
 recommended input configurations
 (table), 3-9
 single-ended connections for floating
 signal sources, 3-13 to 3-14

S

sample-interval timing, 3-26 to 3-27

signal connections
 analog input signal connections, 3-5 to
 3-15
 bipolar signal range vs. gain (table),
 3-5
 common-mode signal rejection, 3-15
 differential connections
 floating signal sources, 3-11 to
 3-13
 grounded signal sources, 3-10 to
 3-11
 purpose and use, 3-10
 when to use, 3-10
 exceeding maximum input voltage
 ratings (warning), 3-5
 floating signal sources, 3-7

- ground-referenced signal sources, 3-7 to 3-8
 - input configurations, 3-8 to 3-15
 - instrumentation amplifier, 3-6 to 3-7
 - pins, 3-5
 - recommended input configurations (table), 3-9
 - single-ended connections
 - floating signal sources (RSE configuration), 3-13 to 3-14
 - grounded signal sources (NRSE configuration), 3-14 to 3-15
 - purpose and use, 3-13
 - when to use, 3-13
 - types of signal sources, 3-7 to 3-8
 - unipolar signal range vs. gain (table), 3-6
 - analog output signal connections, 3-16 to 3-17
 - DAQ and general-purpose timing signal connections
 - DAQ timing connections, 3-25 to 3-29
 - general-purpose timing connections, 3-29 to 3-33
 - pins, 3-25
 - power connections, 3-33
 - specifications and ratings, 3-32
 - digital I/O signal connections
 - illustration, 3-19
 - logical inputs and outputs, 3-18
 - pins, 3-17
 - Port C pin connections, 3-19 to 3-20
 - timing specifications, 3-20 to 3-24
 - mode 1 input timing, 3-22
 - mode 1 output timing, 3-23
 - mode 2 bidirectional timing, 3-24
 - I/O connector
 - exceeding maximum ratings (warning), 3-1
 - pin assignments (figure), 3-2
 - signal descriptions (table), 3-3 to 3-4
 - single-channel data acquisition, 4-9
 - single-ended connections
 - floating signal sources (RSE configuration), 3-13 to 3-14
 - ground-referenced signal sources (NRSE configuration), 3-14 to 3-15
 - purpose and use, 3-13
 - when to use, 3-13
 - software programming choices
 - National Instruments application software, 1-2 to 1-3
 - NI-DAQ driver software, 1-3 to 1-4
 - register-level programming, 1-4
 - specifications
 - analog input, A-1 to A-5
 - analog output, A-6 to A-7
 - bus interface, A-9
 - digital I/O, A-8
 - environment, A-10
 - physical, A-9
 - power requirements, A-9
 - timing I/O, A-8 to A-9
 - square wave generation, 3-29
 - STB* signal, 3-20
 - system noise, A-5
- ## T
- technical support, B-1 to B-2
 - theory of operation
 - analog input, 4-5 to 4-11
 - circuitry, 4-6 to 4-7
 - illustration, 4-5
 - DAQ rates, 4-10 to 4-11
 - analog output, 4-11 to 4-12
 - circuitry, 4-12
 - illustration, 4-11
 - DAC timing, 4-12
 - block diagram of PCI-1200, 4-1

- digital I/O, 4-12 to 4-13
 - circuitry (figure), 4-13
 - functional overview, 4-1 to 4-2
 - PCI interface circuitry, 4-2 to 4-3
 - block diagram, 4-3
 - timing, 4-3 to 4-5
 - circuitry (figure), 4-4
 - time-lapse measurement, 3-30
 - timing circuitry
 - illustration, 4-4
 - theory of operation, 4-3 to 4-5
 - timing I/O specifications, A-8 to A-9
 - timing signal connections
 - DAQ timing connections, 3-25 to 3-29
 - EXTCONV* signal, 3-25 to 3-27
 - EXTCONV* signal timing (figure), 3-25
 - EXTTRIG signal, 3-26 to 3-27
 - EXTUPDATE* signal, 3-28 to 3-29
 - interval scanning, 3-27 to 3-28
 - pins, 3-25
 - posttrigger and pretrigger modes, 3-26 to 3-27
 - posttrigger timing (figure), 3-26
 - pretrigger timing (figure), 3-27
 - general-purpose timing signal connections
 - event-counting, 3-29
 - with external switch gating (figure), 3-30
 - frequency measurement, 3-30 to 3-31
 - illustration, 3-31
 - GATE, CLK, and OUT signals, 3-29 to 3-33
 - pins, 3-25
 - pulse-width measurement, 3-30
 - specifications and ratings, 3-32
 - square wave generation, 3-29
 - time-lapse measurement, 3-30
 - timing requirements for GATE, CLK, and OUT signals (figure), 3-33
 - timing specifications, digital I/O, 3-20 to 3-24
 - mode 1 input timing, 3-22
 - mode 1 output timing, 3-23
 - mode 2 bidirectional timing, 3-24
 - trigger, digital, A-9
- ## U
- unipolar signal range vs. gain (table), 3-6
 - unpacking the PCI-1200, 1-6
- ## V
- VirtualBench application software, 1-2 to 1-3
- ## W
- WRT* signal, 3-21